



**AMERICAN  
KENNEL CLUB®**

June, 2014

To All AKC® Show/Trial-Giving Clubs,

Your response to the 2008 edition of the SHOW/TRIAL MANUAL was overwhelmingly positive, and you used it well in producing high-quality events. The Events Operation staff now offers the 2014 edition, which has been updated with new information, illustrations and forms. This is the first edition published digitally.

Once again, members of our sport contributed to the effort of updating the Manual, particularly with the constructive questions you have asked and suggestions you have made. We would like to express our appreciation to the clubs and their members, the AKC Executive Field Representatives, Superintendents, and our in-house staff.

This Manual has the latest information about AKC rule and policy changes, with precise footnotes and a robust index to help you find the information you're seeking. Please continue to assist us by asking questions and making suggestions. Forward any ideas and suggestions you have to our office, so that we can continue to give you one of the American Kennel Club's most useful publications.

Sincerely,

Bri Tesarz, Programs Manager  
AKC Event Operations

# AKC Show/Trial Manual

2014



© Copyright 1979, 1987, 1996, 2000, 2003, 2005, 2008, 2014 The American  
Kennel Club



## 1: Table of Contents

### 1: Table of Contents

### 2: The Event Committee

Planning and Organization _____	2-3
Records _____	2-5
Event Committees _____	2-5
Show Chair _____	2-7
Assistant Show Chair _____	2-10
Each Committee Chair _____	2-10
Obedience/Rally Chair _____	2-10
Chief Steward _____	2-11
Grounds/Equipment Chair _____	2-12
Parking Chair _____	2-14
Concessions Chair _____	2-15
Advertising and Catalog Chair _____	2-16
Trophy Chair _____	2-17
Publicity Chair _____	2-19
Emergency Response Coordinator (Safety Chair) _____	2-20
Hospitality Chair _____	2-22
Treasurer _____	2-23
Education _____	2-24
Executive Field Representatives _____	2-24
Photographer _____	2-25

### 3: Financial and Contingency Planning

Financial Planning _____	3-2
Contingency Planning _____	3-2

### 4: The Show Site

Selecting the Site _____	4-2
Utilizing the Site _____	4-4
Setting Up the Rings _____	4-4

Tenting _____	4-6
Traffic Control and Parking _____	4-7
Sanitation Requirements _____	4-9
Grooming _____	4-10
<b>5: Online Event Management</b>	
Online Event Management _____	5-2
Event Management _____	5-2
Submitting a Judging Panel _____	5-3
Additional Information for an Event _____	5-4
<b>6: Assembling a Judges Panel</b>	
Selecting the Judges Panel _____	6-2
Judges' Assignments _____	6-4
Finances _____	6-6
Communications with Judges _____	6-7
Club's Responsibility to the Judge _____	6-8
Judge's Responsibility to the Club _____	6-8
<b>7: Scheduling Judging</b>	
Setting up the Schedule _____	7-2
Judging Changes _____	7-5
<b>8: Additional Classes and Special Attractions</b>	
Obedience Trial Classes with a Show _____	8-2
The Miscellaneous Class _____	8-2
Junior Showmanship Classes _____	8-3
Specialty Clubs _____	8-3
Non-Regular Classes _____	8-7
Special Attractions _____	8-10
<b>9: Event Publications</b>	
Premium List _____	9-2
Judging Program _____	9-5
Catalog _____	9-8
<b>10: Required Items for Event Operations</b>	
Deadlines _____	10-2
Event Operations Approval _____	10-3
Site Layouts _____	10-8
Event Records _____	10-9
Materials Required at the Event _____	10-9
<b>11: Show Superintendents and Secretaries</b>	
Event Entries _____	11-2
Records _____	11-5

Superintendents' Contracts _____	11-6
Package Contracts - Superintending Services _____	11-8
<b>12: Event Committee Hearings</b>	
The Event Committee _____	12-2
The Hearing Report _____	12-4
The Accused _____	12-4
<b>13: Appendix</b>	
<b>Appendix A: Address and Telephone Directories</b> _____	<b>13-3</b>
AKC Telephone Directory _____	13-4
Licensed Superintendents _____	13-6
Miscellaneous Addresses _____	13-8
Dog Show Photographers _____	13-9
Stewards' Organizations _____	13-11
Tenting Companies _____	13-12
<b>Appendix B: Checklists</b> _____	<b>13-13</b>
Event Checklist _____	13-14
Cluster Checklist _____	13-20
Use of Motorized Vehicles at AKC Events and the ADA _____	13-22
Americans with Disabilities Compliance Checklist _____	13-23
Dealing with Misconduct _____	13-26
Site Inspection Checklist _____	13-28
<b>Appendix C: Reference</b> _____	<b>13-31</b>
Corresponding Date Table _____	13-33
Official AKC Titles for Catalog _____	13-34
Class Divisions _____	13-37
Cluster Site Guidelines _____	13-42
Cluster Site Inspection Guidelines _____	13-43
Judging Ramp Specifications _____	13-47
Site Layouts _____	13-49
<b>Appendix D: Example Correspondence and Forms</b> _____	<b>13-55</b>
Event Financial Planning Sheet _____	13-57
Host Club (Permissions) Letter _____	13-56
Judge's Availability Inquiry Letter _____	13-57
Judging Confirmation Letter _____	13-58
Judging Contract _____	13-59
Hospitality: Judges Information Sheet _____	13-60
Dog Show Photography Agreement _____	13-61
Letter for Radio Coverage _____	13-62
Press Release for Print Media _____	13-63

Dogs in Unventilated Vehicles _____	13-64
Crate Identification Labels _____	13-67
<b>Appendix E: Sample Show Documents _____</b>	<b>13-69</b>
Judges Books _____	13-70

**14: Index**



## 2: The Event Committee

<b>Planning and Organization</b> .....	<b>2-3</b>
The Challenge .....	2-3
The Team .....	2-3
Dealing with People .....	2-4
Dogs Disqualified by Event Committee.....	2-4
<b>Records</b> .....	<b>2-5</b>
<b>Event Committees</b> .....	<b>2-5</b>
Committee Size .....	2-6
Committee Members Exhibiting at Events .....	2-6
<b>Show Chair</b> .....	<b>2-7</b>
Qualifications .....	2-7
Responsibilities.....	2-8
Day of the Event.....	2-9
After the Event.....	2-10
<b>Assistant Show Chair</b> .....	<b>2-10</b>
Responsibilities.....	2-10
<b>Each Committee Chair</b> .....	<b>2-10</b>
Responsibilities.....	2-10
<b>Obedience/Rally Chair</b> .....	<b>2-10</b>
Qualifications .....	2-10
Responsibilities.....	2-11
Day of the Event.....	2-11
<b>Chief Steward</b> .....	<b>2-11</b>
Qualifications .....	2-11
Responsibilities.....	2-12
Day of the Event.....	2-12
<b>Grounds/Equipment Chair</b> .....	<b>2-12</b>
Qualifications .....	2-12
Responsibilities.....	2-13
Day of the Event.....	2-14
<b>Parking Chair</b> .....	<b>2-14</b>
Qualifications .....	2-14



Responsibilities .....	2-14
Day of the Event .....	2-15
<b>Concessions (Vendor) Chair _____</b>	<b>2-15</b>
Qualifications .....	2-15
Responsibilities .....	2-15
Day of the Event .....	2-16
<b>Advertising and Catalog Chair _____</b>	<b>2-16</b>
Qualifications .....	2-16
Responsibilities .....	2-16
Day of the Event .....	2-17
<b>Trophy Chair _____</b>	<b>2-17</b>
Qualifications .....	2-17
Responsibilities .....	2-18
Day of the Event .....	2-19
<b>Publicity Chair _____</b>	<b>2-19</b>
Qualifications .....	2-19
Responsibilities .....	2-19
<b>Emergency Response Coordinator (Safety Chair) _____</b>	<b>2-20</b>
Qualifications .....	2-20
Responsibilities .....	2-20
Day of the Event .....	2-21
Veterinary Requirements .....	2-21
<b>Hospitality Chair _____</b>	<b>2-22</b>
Qualifications .....	2-22
Responsibilities .....	2-22
Day of the Event .....	2-22
After the Event.....	2-23
<b>Treasurer _____</b>	<b>2-23</b>
Responsibilities .....	2-23
Day of the Event .....	2-23
After the Event.....	2-24
<b>Education _____</b>	<b>2-24</b>
<b>Executive Field Representatives _____</b>	<b>2-24</b>
<b>Photographer _____</b>	<b>2-25</b>

---

# Planning and Organization

## The Challenge

Putting on the best event possible is one of the greatest challenges for any club. Structuring the Event Committee correctly enables the club to meet this challenge. The committee should be large enough to give attention to all details, but small enough to accomplish tasks without placing too great a workload on too few individuals.

## The Team

A dog show or obedience/rally trial is a team effort. The AKC establishes the rules and guidelines; the event-giving club fulfills these requirements and provides overall management and production through the Event Committee, the judges, and superintendents or show secretary.

A good working relationship between members of the team will result in a better event. A committee must be unified and dedicated to the production of the best event possible.

Members of the Event Committee represent the entire club. The reputation of a club and its event are dependent on the efforts of the committee. Impressions that exhibitors, spectators and judges take home from the event are a direct reflection of the efforts of the club and the sport in general.

Individuals should be appointed to committees based on experience, the workloads they can handle, and the time they can apportion to each task. Candidates for committee positions must familiarize themselves with the specific duties and responsibilities involved.

Allow for continuity based on experience by appointing committees with both experienced and novice members. Staff the committees with experienced club members who are willing to share their experience and knowledge with those who wish to learn.

Committee members have an opportunity to apply their expertise and to train others for the future. Working on or with an event committee is an excellent way to involve new club members. Those with limited experience should be encouraged to participate; not only will they learn “the ropes” while working on a committee, their enthusiasm can serve to boost and bolster everyone’s morale.

## Dealing with People

Committee members must be diplomatic and be capable of treating each exhibitor courteously. Each problem should be resolved promptly, calmly and rationally.

All club members, particularly club officials, should receive instructions on dealing with the public. All club members should be able to direct them to concessions, restrooms, telephones, and to answer general questions about events and purebred dogs.

The AKC Executive Field Representative, Show Chair, and members of the Event Committee should be kept abreast of all activities concerning the event.

## Dogs Disqualified by Event Committee

The AKC Board of Directors adopted the following regulation to the [Rules Applying to Dog Shows](#). This regulation permits Event Committees to disqualify dogs.

*Any dog, that in the opinion of the Event Committee, attacks a person or dog at an AKC event, resulting in an injury, and is believed by that Event Committee to present a hazard to persons or other dogs, shall be disqualified by the Event Committee pursuant to this section, and a report shall be filed with the Executive Secretary of The American Kennel Club. This disqualified dog may not again compete at any AKC event nor be on the grounds of an AKC event unless and until, following application for reinstatement by the owner to the American Kennel Club, the owner receives official notification in writing from the AKC that the dog's eligibility has been reinstated.*<sup>1</sup>

Although the disqualification is to be determined by the Event Committee, a hearing to determine the disqualification is not required. Following an incident, the Event Committee is to collect any information and statements from involved exhibitors, owners and witnesses. Along with this information the [Dog Aggression - Action by Event Committee](#) form must be completed and submitted to AKC. The committee shall then determine:

1. Was there an attack?
2. Was there an injury?
3. Does the dog present a hazard to persons or other dogs?

If the committee determines these three items to be true and there were no mitigating circumstances that caused the attack, the dog must be disqualified. Once the dog is disqualified, the dog may not compete in any AKC events. The owner of the dog should be notified immediately of the disqualification.

If the Event Committee, in the course of making its disqualification determination, receives information that alleged acts of conduct prejudicial have occurred during or in connection with the club's event then the procedures outlines in the Dealing with

---

<sup>1</sup> Rules Applying to Dog Shows, Chapter 11, Section 8-A

Misconduct booklet must be followed regarding the discipline of the individual(s) involved.

The Event Committee must submit a written report and any supporting documentation to the AKC Executive Secretary within five days.<sup>2</sup> The Event Secretary or Superintendent must FAX a summary of the incident to Event Operations, ATTN: Show Operations (919) 816-4220 and must include this information in their Show Report.

Any questions or requests for reinstatement should be directed to AKC Event Operations, (919) 816-3538 or to eventplans@akc.org.

---

## Records

Past records are the best assistance a club can have. Complete data of previous events helps the committee plan and present a better event. Provide the committees with as much history and data as possible.

Keep a complete file on all events given by the club. Maintain records that detail each topic (e.g., names and addresses of key people, contracts, financial records, correspondence, breakdown of entries, press contacts, suppliers, concessionaires, etc.).

The Committee Secretary, if one has been appointed, keeps the minutes of the committee meetings, and may assist the Chairs in maintaining event records.

---

## Event Committees

An Event Committee with a minimum of five members is required for an AKC licensed point show or obedience trial.<sup>3</sup> Note:

- Committees must have a chair.
- An individual may chair more than one committee.
- Committee responsibilities may be combined or others created as needed.

**The Event Committee has the authority to act in the name of the American Kennel Club to enforce AKC rules on the day of the event.**<sup>4</sup>

Volunteers usually give time and labor with no financial compensation. Provide encouragement so members do their best.

---

<sup>2</sup> Dealing with Misconduct at AKC Events Section V

<sup>3</sup> Rules Applying to Dog Shows, Chapter 6, Section 2

<sup>4</sup> Rules Applying to Dog Shows, Chapter 9, Section 10

## Committee Size

Actual committee size depends on the event and number of members willing to work. Committee size should be appropriate to the individual event. If large committees are necessary, assistant chairs may be appointed to act as a backup, keep records, or perform other tasks.

A detailed organization chart assists in defining responsibilities. An example of the committee structure is:

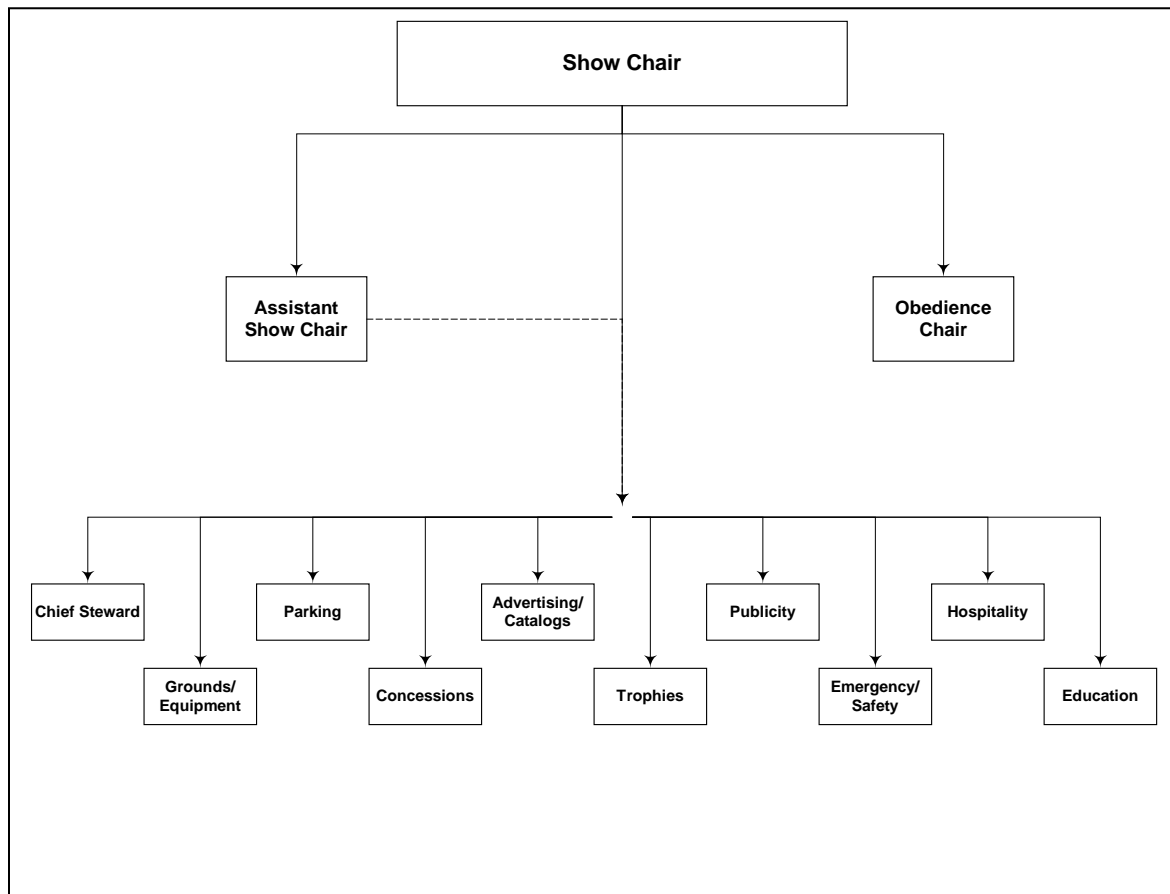

## Committee Members Exhibiting at Events

Whether or not committee members should exhibit at the event is a common question. The following statement is the AKC's response:

*Regarding the question of whether or not club officers or show officials and members of their households should exhibit at their club's show, the AKC has no desire to legislate in this regard, but does expect clubs to seriously consider their own policies on the subject.*

*The AKC recognizes that in some parts of the country there are few shows; consequently an exhibiting restriction placed on club officials is a hardship.*

*However, a club should realize that exhibitors and spectators sometimes arrive at the wrong conclusion when a dog owned or handled by a club officer or show official, or by a member of such person's household, wins at its show. Therefore, clubs should consider an exhibiting restriction for its officers, show chairs, and members of the show committee, as well as for members of their households.*

*In addition to club and show officials, clubs should also give consideration to placing a voluntary restriction on the exhibiting activities of the show photographer. As the show photographer has constant contact with the judges at an event, complaints are received when the show photographer or a member of his or her household exhibits dogs at the show.*

*If a club decides to adopt a restriction, a notice stating which club officers or show officials and members of their households will be ineligible to enter or handle dogs at the show should appear in the premium list.<sup>5</sup>*

Sample wording is

“Dogs owned or co-owned by Officers, Show Chair, members of the Event Committee and members of their households will not be eligible for entry at this event.”

---

## Show Chair

### Qualifications

Knowledge of the AKC's Rules Applying to Dog Shows and the Obedience Regulations (if applicable).

Knowledge of the AKC's policy concerning Emergency Procedures at Events (Disaster and Emergency Plan).

Experience in planning events, gained by serving on various committees.

Ability to apply basic business management practices:

- Set priorities
- Make decisions
- Delegate authority
- Conduct committee meetings
- Compile records

Must be a member of the show giving club.<sup>6</sup>

Ability to meet deadlines.

---

<sup>5</sup> American Kennel Club Policy Manual, Section 4, Paragraph IX.9

<sup>6</sup> Dealing with Misconduct at AKC Events, Section III

Ability to deal with people.

Ability to work within the financial guidelines established by the club, and to evaluate contracts and agreements as necessary.

## **Responsibilities**

Overall responsibility for proper planning, conducting and reporting the results of the show.

Ensure that the event application, judges panel, and other necessary documents are submitted to the AKC by their deadlines.

Ensure that the premium list material is submitted to the show secretary/superintendent by the deadline.

Assign all committee chairs, who are responsible for their own areas.

Assign a Committee Secretary.

Act as the facility/site liaison for the club. Establish and maintain communications with the person responsible for lease of the site.

- Site must be available before and after the actual event hours. Knowledge of facility use before and after the event is an important consideration.
- Requirements for insurance, contract, advance deposits, limitations to site usage, additional rental space, etc. must be determined.
- Extent of owner/management involvement in the event should be established prior to leasing, particularly with regard to required usage of the site's personnel or concessions.
- Any potential problems that might result from the event should be discussed beforehand, allowing the owner/manager to take adequate steps to alleviate them. Periodic reconfirmation should be made, even after club(s) have reached agreement with facility owner/management. Constant communication can help avoid any oversights by the site owner/management.

Determine legal requirements, such as obtaining permits that may be required. Check with local authorities. Agencies that issue permits include, but are not limited to, the local township, health, fire and police departments.

Consider federal, state and local taxes to avoid any possible penalties imposed for failure to follow such requirements.

Contract superintendent or show secretary.

Contract official photographer.

Act as liaison to companion/cluster clubs and specialty clubs.

For all committees responsible for money collection (i.e., Parking, Catalog Sales, etc.), arrange for appropriate starting funds.

Review the AKC procedures detailed in Dealing with Misconduct with all members of the Event Committee, in advance of the event. A guideline for is included on pp. 13-26 - 13-27.

May chair (an)other committee(s).

## Day of the Event

Arrive at least 2 hours before the start of judging. Walk the grounds to be certain that everything is in order.

See that a properly completed and signed copy of the Disaster and Emergency Plan form is available at the event. Copies should also be supplied to all Committee Chairs.

See that the following are provided:<sup>7</sup>

- Rules Applying to Dog Shows
- Rules Applying to Registration and Discipline
- Dealing with Misconduct
- Procedural Checklist
- The Complete Dog Book or a set of all breed standards
- Show/Trial Manual
- Rules, Policies and Guidelines for Conformation Dog Show Judges
- Conformation Junior Showmanship Regulations, Guidelines for Judging Juniors in Conformation, Juniors in Performance Event

Also provide the following when applicable:

- Obedience Regulations, Obedience Judges Guidelines, The Steward in Obedience, Rally Regulations, Rally Judges Guidelines, The Steward in Rally

See to the colors and national anthem before the start of judging.

Meet with the AKC representative, if present, first thing the morning of the show.

Check with all committee chairs to ensure that everything has been completed.

For all committees responsible for money collection (i.e., Parking, Catalog Sales, etc.), arrange for money pickups during the day.

Check in workers and assign tasks.

Check in judges.

See that the ring schedule is maintained.

Address any disputes that may arise.

---

<sup>7</sup> Rules Applying to Dog Shows, Chapter 2, Section 17



## After the Event

Check with the AKC Representative, Superintendent or Show Secretary, and judges for suggestions.

Check event grounds after clean up to be sure everything is in order.

Confirm that all hired personnel have been paid.

---

## Assistant Show Chair

### Responsibilities

Assist Show Chair in all areas. Assume responsibility in the Show Chair's absence.

Chair (an) other committee(s).

---

## Each Committee Chair

### Responsibilities

Report directly to the Show Chair.

Add/update the event checklist each year so that the club will have a customized list for its event. See the Event Checklist example, pp. 13-14 - 13-19.

Prepare a list of specific duties and responsibilities for the day of the event.

---

## Obedience Chair/ Rally Chair

One of the strongest attractions for spectators at a dog show is the obedience/rally trial; people enjoy watching dogs perform these exercises.

When an obedience/rally trial is held in conjunction with a point show, an obedience/rally chair must be established.<sup>8</sup> The appointment may be made by the club's board of directors, or by the Event Committee.

### Qualifications

Must be a member of the trial giving club.<sup>9</sup>

Experience exhibiting or stewarding in Obedience/Rally trials and familiarity with the AKC's Obedience Regulations and Rally Regulations.

---

<sup>8</sup> Rules Applying to Dog Shows, Chapter 6, Section 2.

<sup>9</sup> Dealing with Misconduct, Section III

Knowledge of the AKC's policy concerning Emergency Procedures at Events (Disaster and Emergency Plan).

## **Responsibilities**

Responsible for overall for planning, presentation, and reporting of the obedience/rally portion of the show.

Have a copy, or know how to access the copy, of the Disaster and Emergency Plan that must be available at the event.

Be available in the area of the obedience/rally rings throughout the trial hours.

Work with the Event Committee in selecting and securing obedience/rally judges and stewards.

Coordinate the obedience/rally ring layouts.

Procure and properly place obedience equipment that complies with AKC regulations, including proper maintenance and setup of the obedience/rally equipment in the rings on the day of event. After the event, dismantle and check condition for future events.

Work with the Chief Steward in assigning stewards to the obedience/rally rings.

Secure, display, and make available for presentation the obedience/rally trophies.

## **Day of the Event**

Check in workers and assign tasks.

Check rings, equipment, and judges' materials and other requirements.

For obedience prizes to be awarded based on score, e.g. Highest Scoring Dog in the Regular Classes or the Highest Combined Score in Open and Utility, review the scores to determine the winner of the award. Be familiar with the rules for awarding obedience prizes.<sup>10</sup>

---

## **Chief Steward**

A club member or any other experienced individual may be appointed as Chief Steward, or a stewarding organization may be secured. See the list of Stewards' Organizations, pp. 13-11.

## **Qualifications**

Have stewarding experience and be familiar with AKC rules and regulations, Dog Show Stewards, The Steward in Obedience, and The Steward in Rally.

---

<sup>10</sup> Obedience Regulations, Chapter 1, Sections 21, 22

Be well-versed in recruiting and scheduling stewards.

## **Responsibilities**

Recruit and assign competent stewards. Contact them well in advance.

Remind club members that when they work as stewards, they will usually be unavailable to work at other duties that day.

Inform stewards that they must not steward for any judge under whom they have an entry.<sup>11</sup>

Make ring assignments in advance of the event.

Obtain copies of the judging program, parking passes and admission tickets from the superintendent or show secretary. Mail copies of judging program, parking passes and admission tickets to persons serving as stewards.

## **Day of the Event**

Check in stewards and confirm their ring assignments.

See that all necessary equipment and the judge's bag are located in each ring.

Confirm that each ring has a show catalog.

Obtain lunch tickets from hospitality chair and distribute them to all stewards.

Check rings periodically throughout the day to ensure stewards are doing their jobs properly.

Provide stewards for the groups and Best in Show. The Show Chair usually chooses these stewards.

---

## **Grounds/Equipment Chair**

### **Qualifications**

Ability to supervise people.

Knowledge and understanding of:

- The AKC's Disaster and Emergency Plan policy.
- Conformation and obedience/rally ring layouts.
- Traffic flow and crowd control (works closely with Parking Chair).
- Sanitary and comfort requirements.

---

<sup>11</sup> Rules Applying to Dog Shows, Chapter 18

## Responsibilities

Hire or select people to perform various physical tasks. Schedule workers.

Prepare and lay out grounds. Check the site for holes, high grass, mat requirements and overall ring conditions, etc.

Be familiar with the **American with Disabilities Compliance Checklist**, pp. 13-23 – 13-25.

Arrange access to the site for committee members, the superintendent, exhibitors, vendors or suppliers before the event hours.

Supervise setting up and dismantling of event equipment.

Secure public telephones or access to telephones, with locations and directional signs. (Temporary service should be provided where no service is available; many local-operating companies can arrange this type of service for you.)

Check that public address systems are operating and are located so those announcements reach all exhibitors. Speakers placed too close to individual rings may annoy dogs; speakers too far from ring tents may not be audible under the tent.

Maintain grounds and equipment and supervise clean up of the site during and after the event, including the parking and restroom areas. Ensure that a sufficient number of trash receptacles are distributed around the grounds. Supervise periodic cleaning of all public exercise pens, as well as trash and recycle receptacles.

Arrange transportation and/or storage of club materials or equipment that may be needed for the event, and obtain any additional equipment.

Arrange adequate potable water supply; it may be necessary to have water delivered to the site. Arrange for a supply of ice for emergency situations.

Plan for a judge's table, chairs, and an examination table or judging ramp (if necessary) to be provided in each ring. See *Judging Ramp Specifications*, p. 13-47.

If chairs are provided for exhibitors, this should be stated in the premium list.

Determine limitations, if any, prohibiting crates, private exercise pens, use of flexi-leads and tables in ring tents, grooming areas, and aisles or at ringside. These club rules must be stated in the premium list (see p. 9-4).

Post directional arrows to show site the day before the event.

Order golf carts, if necessary.

Post signs for locating restrooms, telephones, water, etc. A simple map of the show layout should be available for club members and workers, so they may direct the exhibitors to parking, grooming, rings, restrooms, etc.

Secure sanitation facilities or access to sanitation facilities.

Arrange for flowers or plants for rings and club or trophy table.

## Day of the Event

Check in workers and assign tasks. A crew must maintain cleanliness in rings, aisles, restrooms, exercise areas, parking lots and all of the areas throughout the day. Allow enough coverage so that workers may take breaks.

Be sure the unloading area is ready to receive the flow of traffic. Particularly important at indoor sites is that each bay in the loading dock is available, as this is often where the facility parks television/cable trucks, ambulances, cleaning apparatus, etc. Each open bay increases the speed at which exhibitors can unload and move their vehicle out for the next one.

See that all rings, markers, banners and signs have been properly placed. See that exercise pens are properly set up with clean-up tools. Check on restrooms or sanitation facilities.

Be accessible by walkie-talkie or other means throughout the event hours.

Supervise proper clean-up of the show site after the event.

---

## Parking Chair

### Qualifications

Previous service on the Parking Committee or experience parking vehicles.

Unflappable nature, great deal of patience.

Understanding of exhibitors' expectations and time demands.

Knowledge of the local area. In case of emergency, coordinate with Show Chair, Safety Chair, and other Committee Chairs as necessary to help provide local authorities or emergency response personnel and vehicles with clear ingress and egress, crowd control, etc.

### Responsibilities

Plan, supervise and select staff for all parking and unloading. Unloading and parking operations should be quick and efficient.

Plan parking for the handicapped, Event Committee members, judges, stewards, concessionaires, emergency vehicles, RV's and overnight parking. Be familiar with the **American with Disabilities Compliance Checklist**, pp. 13-23 - 13-25.

Mark off parking and no-parking areas (with tape, rope, signs, etc.). Maintain emergency lanes. Ensure that exhibitors park in designated area(s).

Arrange for tow trucks or tractors in case of bad weather.

Include information on campgrounds, rest areas, etc. in premium list and judging program. Visit prospective locations before listing them in any mailings sent to exhibitors.

Manage overnight parking. If no overnight parking is provided at the event site, indicate where vehicles may park for the night.

**Have someone at site the afternoon before the show to park vehicles.** This will prevent problems the day of the event.

Process advance parking reservations, collecting fees, assigning spaces, and returning parking confirmations.

Designate someone to collect parking fees. Parking fees must be turned over to the Treasurer for proper disposition. If proceeds from parking are being donated, indicate this in the premium list and judging program and on a sign posted at the gate.

### **Day of the Event**

Check in workers and assign tasks. Allow enough coverage so that workers may take breaks.

Collect fees at the gate (if applicable). Consider handing out plastic trash bags to all exhibitors upon entry.

Check that all parking areas, emergency lanes, and traffic flow are being maintained.

---

## **Concessions (Vendor) Chair**

### **Qualifications**

Previous experience working with concessions.

Creativity in securing and setting up concession areas.

### **Responsibilities**

Secure vendors and concessions (food, dog supplies, dog food, etc.) for the event. Plan to have food concessions open as early as possible the morning of the event (about two hours before the start of judging) for exhibitors who stay overnight and/or who arrive early.

Work with Show Chair and Show Committee to set vendor rates.

Work closely with Grounds/Equipment Chair to ensure that concession/vendor space does not encroach upon grooming/ring space.

Prepare proposed layout and assign space for each concession/vendor; coordinate with the Grounds/Equipment Chair to ensure that vendors/concessions fit in with the overall plan for the event.

Lay out, measure, and mark individual concession areas. Rope off areas, post signs, or use paint to mark concession space.

Send contracts and collect fees for concession space. As these are usually private contracts between vendors and clubs, clubs may specify particular terms such as “no sale of pinch collars.” Send concessionaires a confirmation and a map of the area showing their reserved space.

### **Day of the Event**

Check concession area and vendors.

Check that vendors’ generators are at least 50 feet away from ring(s).

---

## **Advertising and Catalog Chair**

A successful ad campaign can enhance your club’s revenues from your show/trial catalog.

### **Qualifications**

Able to motivate others.

Able to sell ads to potential advertisers.

Creative.

Able to meet deadlines.

### **Responsibilities**

Coordinate club members in both acquiring paid advertisements for the show/trial catalog and assisting with catalog sales. Suggest that ads be solicited from organizations or individuals to which they have given their business throughout the years.

All advertising arrangements should be in writing.

Canvass potential advertisers, usually via a mailing, who may wish to place an ad in the club's catalog. Potential advertisers may include:

- Dog supply companies
- Dog food companies
- Boarding facilities
- Grooming facilities
- The bank where the club maintains an account

- Local merchants
- Restaurants
- Motels and hotels
- Local humane societies
- Other AKC clubs that may wish to advertise their future events
- Any other businesses that club members patronize during the year

Act as coordinator between the advertisers and the printer or superintendent/show secretary.

Receive the ads and submit them to the printer prior to the deadline. The format of the ad is usually specified; the actual setup is prepared by the printer.

Return all advertising materials such as photos, cuts, etc. to the advertiser. Ensure that all advertisers receive a copy of their catalog ad.

Send thank you notes to advertisers.

Manage catalog sales.

Bill all advertisers and collect all moneys due; may be coordinated with the club treasurer. If billing is done after the event, a copy of the ad should be attached to the invoice.

If the club is hosting a specialty or supported entry, a revenue-sharing arrangement may be worked out with the specialty club.

## **Day of the Event**

Bring cash boxes or containers for keeping money from sales. Secure cash from the Treasurer for making change.

Confirm that the correct number of catalogs was delivered. Reserve and secure catalogs to be held for club business, e.g., copies for judges, stewards, members, advertisers, etc.

Set up areas for catalog sales.

Check in workers and assign tasks. Allow enough coverage so that workers may take breaks.

## **Trophy Chair**

### **Qualifications**

Willing to solicit trophy donations.

Able to meet deadlines.



## Responsibilities

Secure and display trophies.

Ensure that all trophies are listed correctly in the premium list. Be aware of all deadlines for the submission of material to the printer.

Work within budget supplied by club.

Acquire trophies for the event. Secure perpetual trophies; ensure that they are cleaned and engraved. Trophies may be donated, or contributions may be made toward a general fund. Decide on the type of trophies to be donated. Purchase Best in Show, Group and High in Trial trophies if they are to be offered. All trophy offerings and pledges for contributions to the trophy fund should be confirmed in writing.

Note that trophies in honor of dogs may only be offered in memory of deceased dogs, and trophies in honor of people may only be offered in memory of a deceased person or a person who is no longer an active breeder or exhibitor. Three-time win trophies are only permissible for placements specified in the Rules Applying to Dog Shows,<sup>12</sup> and may not be offered for Sweepstakes or Futurities. A three-time win trophy may be withdrawn prior to retirement if the show-giving club can obtain a written clearance from all winners.<sup>13</sup>

Include accurate descriptions of all trophies in the premium list.<sup>14</sup> If the prize being donated is not properly described in the premium list, it can only be awarded at the show with the permission of the Event Committee and the reason for the exception included in the show report.<sup>15</sup> Prior to the printing of the premium list, carefully proofread all trophy listings.

Bill and collect for trophy donations; may be coordinated with the club Treasurer. If the donor of a trophy published in the premium list fails to furnish the trophy, the club is responsible and must provide a trophy of equal or greater value.<sup>16</sup> If you are depending on others to bring their pledged items the day of the event, it is wise to have a few extra trophies available. If the extras are unused, they can be used at any future events.

Prepare a final report of income and expenditures for trophies.

After the event, inventory the unclaimed trophies. Submit the inventory report to the Show Chair.

---

<sup>12</sup> American Kennel Club Policy Manual, Section 4, Paragraph IV.C; Rules Applying to Dog Shows, Chapter 5, Section 9-11

<sup>13</sup> American Kennel Club Policy Manual, Section 4, Paragraph IV.B

<sup>14</sup> Rules Applying to Dog Shows, Chapter 5, Section 4

<sup>15</sup> Rules Applying to Dog Shows, Chapter 5, Section 6

<sup>16</sup> Rules Applying to Dog Shows, Chapter 6, Section 8

## Day of the Event

Check in workers and assign tasks. Allow enough coverage so that workers may take breaks.

Confirm that all trophies listed in the premium list are on hand, or that a replacement is available.

Set up the trophy table.

If trophies are being presented in the ring, they must be distributed to the appropriate rings or put in the judge's bag. If trophy cards are given, the Chair should ensure that the cards have been distributed to the appropriate stewards/rings. Exhibitors claiming a trophy should be asked to sign the trophy card upon receipt of trophy.

Designate trophy presenters for Groups and Best in Show.

---

## Publicity Chair

### Qualifications

Familiar with local media.

Able to meet deadlines.

Advertising and/or public relations experience is helpful.

### Responsibilities

Develop a budget.

Create, secure and distribute publicity concerning the event.

Obtain free publicity. Contact local radio and television stations that have a policy of announcing special events.

- Local cable television stations may be willing to present all or part of the show and/or pre-show information.
- There are "community bulletin board" web sites that provide non-profits with free or reduced-cost web pages and internet access. Individual club members or other clubs may also have their own web pages where a notice can be posted.
- Radio stations - see the example **Letter for Radio Coverage**, p. 13-62.
- A combination of press announcements, 8x10 photos, follow-up calls, complimentary tickets and personal letters are effective in obtaining favorable media responses. Be available to greet members of the press when they arrive

and to extend your club's hospitality. See the example **Press Release for Print Media**, p. 13-63.

- Local free publications and company bulletin boards are another source of publicity.
- Some facilities have monthly newsletters that can feature your event.

Obtain paid publicity. The club may want to advertise in the *AKC Weekly Wins*, in catalogs of events held by other clubs in the area, and in local newspapers. Be aware of newspaper deadlines.

Contact the town authorities where the event is being held to obtain permission for displaying banners advertising the event. Club members should encourage local merchants to display signs or posters advertising the event. Flyers should be distributed at local events before the club's event.

Provide discount coupons for the club's event to the local merchants, veterinarians, groomers, pet food stores, kennels, etc. Display cardboard posters in their places of business.

Use the [Economic Benefit of Dog Shows](#) brochure to emphasize the importance of the event to the community.

---

## Emergency Response Coordinator (Safety Chair)

### Qualifications

Be familiar with the AKC's policy concerning [Emergency Procedures at Events](#) (Disaster and Emergency Plan).

Knowledge of the local area. In case of emergency, coordinate with Show Chair, Parking Chair, and other Committee Chairs as necessary to help provide local authorities or emergency response personnel and vehicles with clear ingress and egress, crowd control, etc.

### Responsibilities

Ensure that the event complies with local ordinances. Any questions on the current AKC policy should be referred to the Event Operations Department.

Work with club to develop written procedures covering different emergency situations.

At group and all-breed conformation events, clubs are required to have a qualified emergency medical technician (CPR certified) in attendance from one hour prior to the start of judging until completion of all judging.<sup>17</sup>

## Day of the Event

Have at least one properly completed copy of the Disaster and Emergency Plan form readily accessible.<sup>18</sup>

Have multiple copies of emergency telephone numbers, directions to the emergency facilities, the hours that the facilities operate, and information on alternate facilities.

**Make sure there is at least one working cellular telephone available during show hours.**<sup>19</sup>

Check in workers and assign tasks. Allow enough coverage so that workers may take breaks.

Set up a location for emergency vehicles and for the veterinarian (if on the grounds).

If the event will be held in warm weather, distribute flyers and dashboard notices about Dogs in Unventilated Vehicles. See the examples on pp. 13-64 – 13-66.

Distribute crate identification labels if the club wishes to provide or sell them. See Crate Identification Labels, pp. 13-67 – 13-68.

## Veterinary Requirements

Every club that holds a licensed or member event is required to engage one or more veterinarians licensed in the state where the event is held.<sup>20</sup>

The event's official veterinarian must not exhibit, act as agent or handler, or enter a dog he/she owns or co-owns.<sup>21</sup>

At a benched show, at least one of these veterinarians must be in attendance during the entire progress of the show.<sup>22</sup>

At an unbenched event the club has the option of having the veterinarian "on call."<sup>23</sup> If the veterinarian is "on call," it is the club's responsibility to see that the veterinary service is readily available.

The veterinarian's office or an emergency clinic should be located within easy driving distance. Clubs must have available at the superintendent's or show secretary's table, and should provide to the veterinarian if on site, handouts giving the name, phone number, and directions to the nearest emergency clinic. If there is

---

<sup>17</sup> [AKC Board Policy, March 1998](#)

<sup>18</sup> [AKC Board Policy, March 1998](#)

<sup>19</sup> [AKC Board Policy, March 1998](#)

<sup>20</sup> [Rules Applying to Dog Shows](#), Chapter 10, Section 2

<sup>21</sup> [Rules Applying to Dog Shows](#), Chapter 11, Section 12

<sup>22</sup> [Rules Applying to Dog Shows](#), Chapter 10, Section 3

<sup>23</sup> [Rules Applying to Dog Shows](#), Chapter 10, Section 2

no emergency clinic in the area, give information for the most convenient vet's office. Clubs must verify the hours the clinic or office is open and include them in the handout.

---

## Hospitality Chair

### Qualifications

Organized, personable, and accessible.

Previous experience on hospitality committees.

Experience in planning and organizing meals or other social functions.

Experience making travel arrangements.

### Responsibilities

Plan meals, transportation arrangements, hotel accommodations, etc. for judges.

- Visit the prospective host hotel/motel to ensure that its quality is up to standard.
- Send letters to the judges confirming transportation and lodging.
- Make arrangements for pre-event dinner, if any, and breakfast and lunch the day of the event. Inform all judges of those plans.

Send the judges a fact sheet with pertinent local information, such as:

- Information about the host hotel and restaurants in the immediate vicinity of the hotel.
- The usual weather conditions anticipated.
- Detailed travel directions and information on parking.
- Special local attractions (historical sites, scenic parks, factory outlets, etc.).
- A detailed map of the area.

Visit the hotel(s) you will recommend to the exhibitors/spectators to ensure that they are up to standard and that they are willing to accept dogs.

Set up special rates with the hotel(s).

Notify the hotel of times needed for airport transportation (if available).

Mail admission and parking passes to judges.

### Day of the Event

Organize the breakfast for the judges at the hotel or the event site. Provide coffee and tea at the event in the morning.

Arrange transportation of judges to the event, planning for them to arrive about a half-hour before judging is scheduled to begin.

Coordinate committee members to visit the rings periodically to check the needs of the judges and stewards. Flowers and food on judges' tables may attract bees at outdoor events.

- Coolers for cold drinks and bottled water, and a thermos for hot drinks, may be placed in the rings.
- Hospitality packets may be placed in each ring, e.g., towelettes, paper towels, hard candy, etc.

Organize a luncheon for the judges, stewards, club members, and other invited guests. Invited guests may include the AKC Executive Field Representative, photographer, superintendent, show secretary, EMT personnel, etc. Lunch tickets should be given out the day of the event.

Arrange transportation of judges back to the hotel, airport, or to the next event if you are sharing judges with another club.

Distribute lunch tickets.

Coordinate with the Treasurer to distribute expense sheets to the judges.

### **After the Event**

Send thank-you cards to the judges.

---

## **Treasurer**

### **Responsibilities**

It is helpful to supply an expense sheet to the judges the night before or morning of the event, requesting that they complete and return it to the Treasurer by lunch. Coordinate distributing these sheets to the judges with the hospitality chair. This will allow ample time to issue the checks and have them ready as the judges prepare to leave the event. The form could be sent with assignment confirmations or may be included in any welcome materials left at the hotel.

### **Day of the Event**

Set up an "office" at the site to pay appropriate bills approved by Show Chair.

Supply cash advances and change for catalog sales, gate receipts, and any unexpected costs.

Coordinate a cash pick-up schedule with the Show Chair.

## After the Event

Complete a financial report of the event, developed with the assistance of the event committee chairs.

Distribute designated donations to the beneficiary(s), if applicable.

Begin budget cycle for next event by reviewing budgets established for completed event, adjusting figures as needed.

---

## Education

An educational booth may be set up and staffed by club members to educate the public about club activities and the sport of purebred dogs. AKC Videos may be shown at the booth.

The AKC Booth schedule is developed throughout the year and is finalized in late fall for the following year. Requests for the AKC Educational Booth should be submitted to the Director of Club Education.

Dog Show Tours, in which a knowledgeable guide explains to the general public how dog shows are conducted, are also an effective way to educate the public about the sport and fulfills the public education eligibility requirement to hold future dog shows.

Another form of education is the new exhibitor briefings. These briefings should help new exhibitors understand the dog show and feel more comfortable with the sport. The briefing must be publicized in the judging program and should include scheduled times. The briefing should explain the duties of the superintendent or show secretary, the AKC Executive Field Staff, the event committee, the ring steward, ring location, exercise areas, and assist with grooming space. An explanation of dog show classes, points computation, and verification of placements (judges book tear sheets) should be included in the briefing.

---

## Executive Field Representatives

The Judging Operations Department assigns AKC Executive Field Representatives to events; an AKC Executive Field Representative will not attend all events.

Some of the duties and responsibilities of the AKC Executive Field Representative at all-breed or specialty events include:

- Arriving at the event grounds prior to judging.
- Conducting site inspections and recommending changes in event layouts, sites, entry limits, etc.
- Acting as the AKC's liaison.

- Providing insight on policy and rule compliance and first-hand information regarding event operations.
- Acting in an advisory capacity to the Event Committee, exhibitors, breeders and judges.
- Observing and interviewing judges.

Almost every all-breed show has an AKC Executive Field Representative in attendance. Additionally, many specialty shows, obedience trials, and field trials have an AKC Executive Field Representative at the event.

---

## Photographer

The club is responsible for securing an official show photographer. See the list of Dog Show Photographers, pp. 13-9 – 13-10. The photographer should be contacted a minimum of eighteen months in advance; additional time should be allowed for national specialties.

Obtain a copy of the photographer's contract. Any changes and/or additions to it should be agreed to in writing by the club and the photographer. See the example Dog Show Photography Agreement, p. 13-61.

Exhibitors will often request to have a photograph of their dog taken with the judge presenting the ribbon. Judges are usually agreeable to such requests, provided they do not delay judging. In those cases where a judge is behind schedule, judging should not be further delayed by taking photographs. Rather, a mutually acceptable time and place should be arranged between the judge and exhibitor, some time after the judge has completed the assignment. If time permits (and depending on the event type), pictures can be taken after Best of Breed or Best of Variety.

If possible, a separate area can be set up for photos. This will also help judges stay on schedule. An added amenity to the photo area is to use a backdrop and flowers to enhance the photos.

Any restrictions placed on the photographer from exhibiting must be listed in the premium list.





# 3: Financial and Contingency Planning

<b>Financial Planning</b> .....	<b>3-2</b>
Budgeting the Event.....	3-2
Contingencies .....	3-2
Cost Control.....	3-2
<b>Contingency Planning</b> .....	<b>3-2</b>
Event Cancellation .....	3-3
Insurance for Dog Events.....	3-3

---

## Financial Planning

Annually, the event-giving club should set up, maintain and review the financial limitations placed on the Event Committee.

### Budgeting the Event

The best budgeting tool the Event Committee can use in planning future events is a complete set of past events financial records, which should be in the club's permanent file. Base the event budget on past income and expense experience.

In preparing the financial planning sheet for an event, the income and expenses could be divided as shown in the Event Financial Planning Sheet on p. 13-55.

### Contingencies

The Event Committee must have some flexibility to deal with problems or changes that may require variance from the budget. Both the Event Committee and the club should agree in advance to the methods for taking action to meet any financial emergency.

Consider setting aside an amount of money as a contingency fund. This will:

- Allow payment of up-front event costs without straining the club's normal operating budget.
- Insure the club against emergencies or unexpected expenses that may affect event income.
- Allow the club to purchase necessary equipment, provide special services or activities, and provide trophies at the event.

### Cost Control

It may be beneficial to coordinate expenses with companion or cluster events.

---

## Contingency Planning

The committee should be prepared for any situation, for example, arranging for tow trucks to remove vehicles from loading areas or muddy parking lots in the event of bad weather at an outdoor event. Alternate sites should be considered in case of a last-minute cancellation at the event site.

Inquiries concerning contingency planning should be addressed to the Event Operations Department.

It is good practice to be sure that copies of all contracts are kept by multiple club officials (i.e., Show Chair & Treasurer should both have copies) in the event one person is not able to attend the event.

## Event Cancellation

Situations may arise when it is advisable to cancel an event - "the show must go on" does not prevail. **The safety of both the exhibitors and the dogs is paramount in making this decision.**

Different weather conditions bring varying concerns to our events, and situations such as, but not limited to, extreme heat, snowstorms, or hurricanes must be considered for the health and safety of our dogs, judges, and fanciers.

A question has been raised about whether a club may cancel an event due to extreme heat conditions. The AKC believes that the well-being of dogs and participants is of utmost importance, and that the club may take such action when necessary. A notice to this effect should be included in the premium list to inform exhibitors of the possibility of a cancellation for adverse conditions and to address refunds of entry fees. Examples of wording used by many clubs are:

"If because of riots, civil disturbances, or other acts beyond the control of the management it is impossible to open or complete the show, no refund of entry fee will be made."

"The well-being of the dogs, exhibitors, and spectators is of paramount importance, and in the event it is necessary to cancel or stop the event before completion, no refund of entry fee will be made."

Should the decision be made to cancel the show for circumstances that endanger the health and safety of the dogs it should be reported to the Weekend Club Hotline by an AKC Representative or an official of the hosting club. The Weekend Club Hotline can be reached at 1-800-252-7894.

Exhibitors registered in an upcoming show that are worried about conditions that would warrant a cancellation can check the status of shows by calling the Event Cancellation Hotline which can be reached at 1-877-252-3229.

## Insurance for Dog Events

It is important that clubs have appropriate insurance for their events and activities.

Consult with a local agent or you may find a source for your clubs insurance on the AKC website, [www.akc.org](http://www.akc.org), under Clubs & Delegates icon on the home page. This service is provided by Equisure, Inc. in cooperation with the AKC. Contact information this company can be procured from p. 13-8.



## 4: The Show Site

<b>Selecting the Site</b> .....	<b>4-2</b>
Evaluating a Prospective Site .....	4-2
Affordability .....	4-2
Site Approval .....	4-2
Type of Site.....	4-3
Indoor Sites.....	4-3
Size .....	4-3
Conditions .....	4-3
Outdoor Sites.....	4-3
Weather Conditions.....	4-3
Site Preparation.....	4-4
<b>Utilizing the Site</b> .....	<b>4-4</b>
<b>Setting Up the Rings</b> .....	<b>4-4</b>
Obedience/Rally Rings .....	4-5
Breed Rings.....	4-5
Ring Size.....	4-5
Group Rings.....	4-6
<b>Tenting</b> .....	<b>4-6</b>
Tenting Layout.....	4-6
<b>Traffic Control and Parking</b> .....	<b>4-7</b>
Indoor Sites.....	4-8
Parking .....	4-8
Unloading/Loading Zones.....	4-8
Outdoor Sites.....	4-9
<b>Sanitation Requirements</b> .....	<b>4-9</b>
Outdoor Toilet Facilities .....	4-9
Exercise Pens.....	4-9
<b>Grooming</b> .....	<b>4-10</b>

---

## Selecting the Site

Dog shows and their related events will have a significant positive economic impact on the community where they are held. The AKC's brochure on the [Economic Benefit of Dog Shows](#) is a tool that the club can use when speaking to potential site management.

### Evaluating a Prospective Site

Before reserving the facility, imagine it in actual use. Picture crates and equipment arriving, people and dogs in the aisles, exhibitors, judges, and spectators filling the site as they would on the day of the event. Draw on your show secretary's or superintendent's experience in laying out show sites, and discuss the show site with your local AKC Executive Field Representative.

When evaluating a prospective site, consider all aspects of a quality event. The facility/site should:

- Be within the club's geographic area of operation.<sup>1</sup>
- Be large enough to accommodate the expected entry.
- Provide adequate access roads onto the grounds.
- Provide ample parking for judges, the Event Committee, exhibitors, and spectators, including a specified area for motor homes.
- Provide adequate sanitary facilities for people and dogs.
- Provide an area convenient to the site for unloading/loading.
- Be in usable condition. In some cases equipment may have to be moved and the facility cleaned prior to the event.

#### Affordability

Attractive facilities may be secured at reasonable rates if the show is planned for a time when the facility has little business.

### Site Approval

Any site not previously used for an all-breed or group club event must be visited by an AKC Executive Field Representative prior to approval by the Event Operations Department. A site diagram (detailed layout) must be provided at the time the event application is submitted to the AKC's Event Operations Department with ring size and aisle widths and location of all amenities. If there are possible problems that may occur with the parking, a layout and parking plan should also be submitted. Approval from the Events Operations Department must be attained if any change of date or venue location is required.

---

<sup>1</sup> Rules Applying to Dog Shows, Chapter 2, Section 3; [AKC Board Policy, September 1996](#)

## **Type of Site**

The three types of sites are indoor, outdoor, and a combination. Each site must be able to accommodate the estimated entry. When a combination indoor/outdoor site is used, the breeds and/or classes to be judged outdoors must be specified in the premium list.

## **Indoor Sites**

Indoor sites minimize weather problems, have restrooms, and often provide food concessions. Clubs holding shows at indoor sites must not depend on favorable weather conditions to accommodate necessary grooming space outdoors.

### **Size**

Indoor sites are usually smaller than outdoor sites. There should be adequate ring, grooming and aisle space.

### **Conditions**

There should be:

- adequate lighting
- heat and air conditioning
- ventilation
- water
- adequate number of rest rooms
- exercise pens, see pp. 4-9 - 4-10.

## **Outdoor Sites**

Outdoor sites are usually larger than indoor sites. More space can be provided for exhibiting, grooming and parking.

The major disadvantages of outdoor sites are the possibility of inclement weather and the time limits imposed by daylight.

### **Weather Conditions**

Select a date that can be used in weather conditions normal for that time of year.

The National Weather Bureau service gives complete data on hundreds of reporting stations in every state, including average temperature and precipitation amounts by day of the year. The National Weather Bureau is usually listed in the front of the local telephone directory; this information is also available by accessing the web site [www.weather.com](http://www.weather.com).

## Site Preparation

Outdoor sites require special preparation, which can raise the cost of an outdoor event. Outdoor sites may require tenting. Grounds may have to be mowed and raked, and holes filled and leveled; damage done to the grounds by vehicles in inclement weather will have to be repaired. Comfort and sanitary facilities may have to be brought to the site. Provisions must be made for electricity and telephones. Potable water must be readily available, and food provisions usually have to be brought to the site.

---

## Utilizing the Site

Utilizing the site to its best advantage is not a simple task. Consult the event superintendent (when using one) for advice, and talk with the local AKC Executive Field Representative.

The main centers of activity are the rings and grooming areas. Parking areas, restrooms, food concessions, traffic flow and unloading must be arranged so they do not impede event activity. Evaluate these areas for possible improvement while the show is in progress and immediately after the event; discuss this with the AKC Executive Field Representative. Record the recommendations for improvement.

Arrange with the manager of the facility to allow the superintendent, exhibitors, handlers and concessionaires onto the event grounds or into the building the day before the event. A club member **must** be present while individuals are allowed admittance.<sup>2</sup>

It is the club's responsibility to show early arrivals where to park and set up. If left unsupervised, they might park and set up in areas that the club intended for other uses.

---

## Setting Up the Rings

Safe and adequate conditions for exhibiting must be provided.

- At indoor shows, a non-slip surface providing maximum safety for exhibitors and dogs should be provided. Matting should provide adequate width and area for presenting and gaiting the dogs. It is strongly suggested that you ask the superintendent to put extra matting at the corners and secure all matting; this will help prevent tripping.
- At outdoor shows, clean, level rings with short grass.
- Vehicles and generators must be at least 50' from all rings.

---

<sup>2</sup> AKC Policy Memo, April 27, 1979

If your club will be sharing a site with other clubs, try to not change the ring numbers from show to show. Not only can this confuse exhibitors, it can create havoc with parking.

## Obedience/Rally Rings

Obedience rings should be as free as possible of any obstructions such as columns and tent poles. Obedience/Rally ring size & condition requirements are outlined in the *Obedience/Rally Trial Manual*.

## Breed Rings

### Ring Size

Both clubs and superintendents/show secretaries need to evaluate the size of the rings against the number of entries. Use the previous year's entries as a guide. Too often large entries are crammed into small rings. This can cause delays in judging and hamper exhibitors entering and exiting the rings. The size of each ring should accommodate the largest breed to be exhibited. The following are suggested guidelines.

	Width in Feet	Unobstructed Length in Feet	Obstructed Length in Feet
All Toy Breeds	24'	32'	42'
Terrier, Hound and Non-Sporting Breeds	32'	40' larger breeds 50'	50' larger breeds 58'
Sporting, Working and Herding Breeds	40'	48'	58'
Specialty Shows (except Toy and Giant Breeds)	48'	64'	74'
Obedience <sup>3</sup>	40'	50'	50'

Clubs may use the above guidelines after considering all relevant factors, such as:

- Available space
- An unusually large or small number of entries in some breeds
- The judges' assignments

Pay special attention to the width of aisles surrounding the rings. AKC policy requires a minimum of 10 feet; however, local ordinances may require more. In areas where heavy foot-traffic or congestion is expected, cross-aisles should be provided to ease access to all rings. Some aisles may be restricted to exhibitors only.

Provide viewing areas around the rings. A ring that is bounded by aisles on two or more sides permits more people to see the judging.

---

<sup>3</sup> Obedience Regulations, Chapter 1, Section 32



## Group Rings

Rings should be enlarged or combined to make a group ring.

Group rings should be large enough to accommodate the largest number of breeds in any group to be judged.

When combining rings on a show grounds or arena layout, thought must be given to entrance and exit of exhibitors and dogs. Be sure that they have ready and safe access.

---

## Tenting

The AKC's policy on providing tenting/shade is:<sup>4</sup>

While the monetary cost of renting, transporting, erecting and disassembling tents can be very high, this cannot compare to the concerns of canine and human health and well being. The AKC is greatly concerned about the welfare of dogs, exhibitors and judges participating in events during inclement or hot weather, and we expect clubs to provide some type of adequate shade at sites which do not have a reasonable amount of protection from the heat.

Prior to arranging for tenting, consult the site management for permission, as some venues have underground cables, sprinklers or other situations that must be addressed before setting up tents. Consult local authorities to determine whether there are ordinances governing tenting, e.g. fireproofing, and whether permits are required.

The club must be very exact and specific about their tenting requirements when securing tenting. Clubs may sometimes secure tenting through the show superintendent or through a separate contract with a tenting company. There are tenting companies in most metropolitan areas; information may be obtained by consulting the telephone directory. There is a list of Tenting Companies on p. 13-12.

## Tenting Layout

Tenting layouts can be divided into two categories:

- Separate tenting for ring area and grooming area. A layout using separate tents for grooming and ring coverage is more efficient than combining both grooming and rings under the same tent.
- A single tent for both ring and grooming areas.

Additional tenting may be necessary for the following:

- Officials' area (club, chief steward, superintendent, etc.).

---

<sup>4</sup> AKC Policy Memo, January 31, 1994

- Obedience area (sides or a solid barrier for obedience exhibitors to go behind during group exercises, and an area for dogs waiting to enter the ring).
- Gate and admission area.
- Catalog sales area.
- Officials' luncheon area.
- Public refreshment/concession area.
- Specialty show areas when a specialty is held in conjunction with an all-breed show.

When laying out tenting for obedience rings, remember that stakes are not allowed in the ring area.<sup>5</sup>

For laying out tenting for areas of combination grooming/ring tents, these guidelines are recommended:

- Two-thirds of the average outdoor entry will usually require tenting area (e.g., if a show has 1,500 entries, provision should be made for sheltering approximately 1,000 entries under tenting). One-third of the average outdoor event entry may be kept in vans, RV's, etc., and brought directly to and from the ring area.
- Of those entries requiring tenting space, approximately one-quarter will be large dogs (this may vary if the club is having large breed specialties, supported entries, sweepstakes, etc.). The area required for large dogs will be approximately 10 square feet per dog.
- The area required for smaller dogs will be approximately half the area required for larger dogs (5 square feet), since crates can be stacked. Exhibitors should be encouraged to stack crates. Personnel engaged in unloading dogs should know the tent layout for proper placement of crates.

---

## Traffic Control and Parking

Traffic control and parking are dictated by the existing parking areas, local garages, streets, etc. When there are inadequate parking areas within the event site, other parking locations must be found.

Regulations for on-street parking can be determined through the local police department.

If permission is obtained from the local authorities well in advance, streets may be closed down or rerouted on the day of the event to provide better traffic flow in unloading and parking areas.

Allow for ease of access for emergency vehicles.

---

<sup>5</sup> AKC Policy Memo, January 31, 1994

Well in advance of the event, provide for towing or removal of vehicles stuck because of inclement conditions, and vehicles blocking traffic lanes, loading/unloading zones, etc.

Use graphics and signs at the event site to indicate traffic direction, unloading areas, event grounds limitations, etc. A site layout in the judging program is helpful.

Layout of gate facilities should allow direct access to and from the event site. To help avoid traffic backups at the entry gate, areas for collecting admissions, parking fees and catalog sales money should be set up well inside the gate. This will help prevent a traffic jam on the street(s) leading to the site.

Parking areas should be designated as either exhibitor or spectator, allowing the exhibitors closer proximity to the ring and grooming area.

Parking areas should be measured and laid out to allow for automobiles, vans, campers, RV's, trailers and buses. The last four categories require at least 50% more space than automobiles. Consider the space taken by awnings attached to these vehicles.

Reserve an adequate number of parking spaces near the event site for the handicapped. See the Americans with Disabilities Compliance Checklist, pp. 13-23 - 13-25. If there are no designated spaces close to the facility, check with the site management. They can also help you determine an average number of handicapped that may be attending. Clubs are not required to reserve handicapped spots for RV's or buses; these vehicles do not fall within ADA guidelines. Vans, however, do fall within the guidelines.

## **Indoor Sites**

The building management should be consulted about your plans to handle traffic.

### **Parking**

Past event records should indicate the approximate number of vehicles to be anticipated. Considering this information, parking would be needed for 75% of the entry.

### **Unloading/Loading Zones**

- Since this is an exhibitor's first impression of your event, put extra thought into the flow of traffic in and out of the unloading area.
- Whenever possible, more than one unloading and loading entrance should be used to expedite the arrival and departure of dogs.
- Constant supervision of the loading areas is needed in order to avoid a backup. This area should be staffed by club members, particularly experienced exhibitors,

who understand an exhibitor's needs when unloading, and the need to move vehicles and exhibitors along in a timely manner.

All people supervising the loading area should have a ring layout with them.

Parking and/or exhibitor passes should be used. Few people, if any, will arrive in the early morning hours that are not part of the event, so consider allowing vehicles into the unloading area during this time without being delayed by producing entry passes. The time saved by exhibitors produces goodwill for the club and outweighs the cost of a few admissions.

## Outdoor Sites

Outdoor sites generally provide more flexibility for managing traffic flow and parking. Open fields and close-by streets should be considered in overall planning.

Provide for safe arrival, unloading of dogs, and removal of vehicles from the grooming area. After the start of the event, take extra precautions to ensure that no people or dogs are injured when traffic is moving in the immediate event area.

A distance of at least 50 feet from all rings should be maintained for all vehicles and generators.

---

## Sanitation Requirements

The Show Committee is responsible for clean and orderly conditions<sup>6</sup> on the show grounds.

An adequate number of trash containers should be available for proper disposal of waste and placed where they will be used. Personnel should be available to empty trash containers throughout the day.

A method to maintain cleanliness that has been used successfully at some events is to provide clean-up tools at ringside. This allows for immediate clean up without announcements or delays while waiting for an individual to arrive at the ring.

## Outdoor Toilet Facilities

The National Plumbing Code requires one outdoor toilet facility for each 30 persons, when emptied every five days (150-person capacity for a one-day activity).

## Exercise Pens<sup>7</sup>

The AKC Board of Directors has approved the following revision to the Show/Trial Manual to more adequately address exercise area requirements at dog shows.

---

<sup>6</sup> Rules Applying to Dog Shows, Chapter 9, Section 11

<sup>7</sup> AKC Policy Memo, June 20, 1981

All-Breed shows must provide the following:

- Gated exercise pens of sturdy construction with a minimum size of 6' X 8' X 4' (48 sq. ft. for each pen).
- For shows with suitable outdoors exercise areas and clean-up supplies the following number of ex-pens must be provided based on the number of entries:
  - 0 – 1,000 dogs – 2 ex-pens
  - 1,001 – 2,000 dogs – 4 ex-pens
  - 2,001 – 3,000 dogs – 6 ex-pens
  - 3,001 – 4,000 dogs – 8 ex-pens
- For shows without suitable outdoors exercise areas the following number of ex-pens must be provided based on the number of entries:
  - 0 – 600 dogs – 2 ex-pens
  - 601 – 1,200 dogs – 4 ex-pens
  - 1,201 – 1,800 dogs – 6 ex-pens
  - 1,801 – 2,400 dogs – 8 ex-pens
  - 2,401 – 3,000 dogs – 10 ex-pens
  - 3,001 – 3,600 dogs – 12 ex-pens
  - 3,601 – 4,200 dogs – 14 ex-pens

In all cases, a minimum of two ex-pens must be available. In the event of inclement weather at least two ex-pens must be under cover.

Individual sites may require deviation of this requirement. The inspecting AKC Field Staff will approve deviations on a site-by-site basis.

Specialty shows must have a minimum of two exercise pens suitable to the size of the breed.

Any questions regarding these requirements should be directed to AKC Event Operations, (919) 816-3579 or [eventplans@akc.org](mailto:eventplans@akc.org).

---

## Grooming<sup>8</sup>

It is the policy of the AKC to encourage and welcome all exhibitors. Keeping the cost of participating in the Sport reasonable for current as well as potential new competitors is crucial to its future health and growth. At the same time, the Board recognizes the financial pressure faced by many clubs in putting on their events. The Board has therefore established the following policy, effective January 1, 2013, with regards to grooming space:

---

<sup>8</sup> [AKC Board Policy, July 2012](#)

All clubs are required to set aside an area for grooming. “Day-of-event” grooming must be provided that is reasonable in size for the entry of the show. A club holding a conformation event may, at its option, offer reserved grooming/crating space for a fee, provided that it makes available, at no charge in addition to the entry fee for the show, a reasonable amount of grooming/crating space of equal desirability to the exhibitors. Such free space need not include additional services such as the availability of electrical hookups.

Any club desiring to offer such paid reserved grooming space shall submit, with its application to the American Kennel Club for the holding of the event, a plan detailing the paid and unpaid space, which shall be subject to American Kennel Club approval.



## 5: Online Event Management

<b>Online Event Management</b> .....	<b>5-2</b>
<b>Event Management</b> .....	<b>5-2</b>
Online Competition Management System.....	5-2
<b>Submitting a Judging Panel</b> .....	<b>5-3</b>
Judge Panel Planning Tool .....	5-3
Quick Submit .....	5-4
<b>Additional Information for an Event</b> .....	<b>5-4</b>

---

## Online Event Management

The Online Event Management Tool is a way for clubs to submit their application for an event as well as judging panel online to the Event Plans department. This online tool allows for quicker processing of information. The Online Event Management Tool can be found on the AKC website by logging in using the club information at <https://www.akc.org/eventplans>.

Once logged in three choices will become available:

- 1) Manage Event - used to submit the application for the show date.
- 2) Submitting a Judging Panel.
  - a) Quick Submit
  - b) Judge's Panel Planning tool
- 3) Submit additional information for an event.

The Online Event Management Tool was created to reduce time and paperwork involved for processing an application. Although this tool allows for the application and judge's panel to be done online, clubs must still complete and submit a paper copy of the [Special Attraction Application](#) and [Common Site Application](#) (if applicable).

---

## Event Management

The Event Management function is a tool that is used to fill out and submit the application for a corresponding event. In this tool the club is able to submit information such as:

- The names and contact information for show secretary/superintendent and chairperson, and
- Event information such as fees, closing dates, etc.

One enticing feature of the Event Management tool is the replication of the previous year's show officials' information. Once the application has been submitted clubs can move on to the next step of processing a judge's panel.

## Online Competition Management System

Clubs offering Specialty, Junior Showmanship, or Sweepstakes events should utilize the new Online Competition Management System (OCMS) to manage their application and judges panel. OCMS is a more intuitive system designed with input from those using the system regularly. It also allows all clubs to add sweepstakes judges after their initial application has been submitted.



Events that can be managed using OCMS have a blue star on the event listings page.

Golden Retriever Club of America		Fletcher, NC	O	Oct 28, 2014	Oct 1, 2014
Golden Retriever Club of America		Fletcher, NC	SWPC	Oct 28, 2014	Oct 1, 2014
Golden Retriever Club of America		Fletcher, NC	RLY	Oct 28, 2014	Oct 1, 2014
Golden Retriever Club of America		Fletcher, NC	PS/JSHW	Oct 29, 2014	Oct 1, 2014

After any club offering sweepstakes submits their event application, a blue star will appear next to the event allowing the club to manage the sweepstakes classes and judges using OCMS.

Name	NEW! OCMS	Location	Event Type	Event Date	Closing Date
Toy Dog Club of Puget Sound		Enumclaw, WA	LB/O/JSHW/SWPC	Oct 4, 2014	Sep 17, 2014
Toy Dog Club of Puget Sound		Enumclaw, WA	LB/JSHW	Oct 5, 2014	Sep 17, 2014

The [Help](#) link in OCMS provides clubs with detailed instructions on how to work with the system to process an event and judged panel.

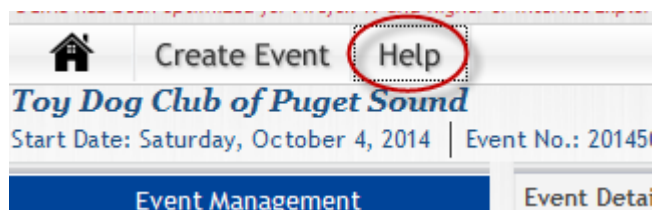

## Submitting a Judging Panel

Submitting the judging panel using the Online Event Management Tool can be done using one of two different online tools:

- Judging Panel Planning tool (JPP).
- Quick Submit

### Judge Panel Planning Tool

The Judging Panel Planning tool is a much more in depth tool that is designed for both planning and submitting the judging panel. The JPP is a Java based program that does more than just submit the application to be processed; JPP allows clubs to manipulate the judging panel to plan upcoming events. The JPP assembles the judge's panel at the club's convenience. The following are features of the JPP system:

- Search for judges
- Add a judge with a pending contract
- Add a judge with a confirmed contract which will be submitted to AKC when the judge's assignment is saved
- View multiple events as the judge's panel is assembled

- View and assess a conflict with the chosen judge
- Identify breeds and classes that have not been assigned a judge

## Quick Submit

Quick Submit is a fast and effective tool for submitting a judging panel. Unlike JPP, this tool is used to submit contracted judges only; it is not a planning tool. The Help link for this tool illustrates step-by-step instructions for use.

### Quick Submit Judges Panel

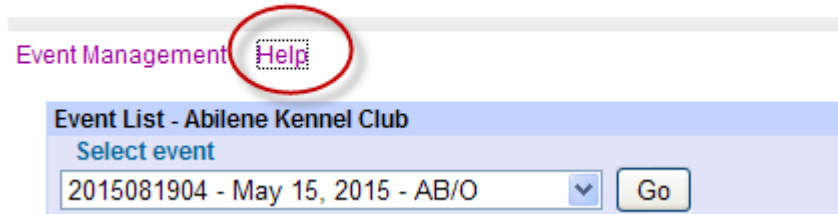

---

## Additional Information for an Event

The third section of the Online Event Management Tool is used to request modifications to an event such as adding/removing non-regular classes or requesting the National Owner-Handled Series, as well as email questions and concerns to an Event Representative.



## 6: Assembling a Judges Panel

<b>Selecting the Judges Panel</b> .....	<b>6-2</b>
Who Selects the Panel .....	6-2
When to Select the Panel .....	6-2
Submitting the Judges Panel .....	6-2
Permit Judges.....	6-2
Visiting Judges.....	6-3
<b>Judges' Assignments</b> .....	<b>6-4</b>
Travel.....	6-4
Assignment Limitations.....	6-4
Division of a Breed Assignment.....	6-5
Judging Conflicts .....	6-5
Breed Judging .....	6-5
<b>Finances</b> .....	<b>6-6</b>
Contracts .....	6-6
Cost Estimation.....	6-6
<b>Communications with Judges</b> .....	<b>6-7</b>
<b>Club's Responsibility to the Judge</b> .....	<b>6-8</b>
<b>Judge's Responsibility to the Club</b> .....	<b>6-8</b>

---

## Selecting the Judges Panel

The judges panel is one of the most important factors to consider when planning an event.

### Who Selects the Panel

Each club selects its own panel. Some clubs select their judges by a vote of the membership; others delegate the job to the Event Committee, to a Judges Selection Committee, or to the Show Chair.

In the case of a designated specialty, the specialty club may be invited to submit the names of several judges or to choose the judge for its particular breed from the all-breed club's panel.

### When to Select the Panel

Clubs should contact judges well in advance. Some clubs do so as much as two years or more prior to the event.

### Submitting the Judges Panel

Clubs should submit the judges panel when the club is in possession of a signed contract from each judge.

The panel must be submitted to the AKC no later than 18 weeks prior to the **closing date** for entries.<sup>1</sup> For designated specialties, all arrangements between the specialty club and the all-breed club regarding judges (selection, assignment, payment, etc.) should be in writing. The all-breed club is responsible for submitting the entire panel.

Panels may be submitted with the judges for some breeds listed as "pending". This option should not be used when a judge has not returned a contract, but only when a judge has not yet been selected.

### Permit Judges

Permit judges who are approved for fewer than all the breeds within a group sometimes find it difficult to obtain assignments. Since these individuals constitute the future of the sport of judging dogs, the AKC's Board of Directors encourages clubs to provide opportunities for permit judges.

For all-breed and group clubs that engage at least four permit judges who are approved for fewer than all the breeds within a group at the time the contract is

---

<sup>1</sup> Rules Applying to Dog Shows Chapter 4, Section 1

signed, credit may be given to the club for one of the educational activities required for permission to hold an event the following year.

For credit for educational activities, the recommended number of provisional judges to use is:

- For entries fewer than 1,000 dogs, use a minimum of four permit judges.
- For entries between 1,000 and 2,000 dogs, use a minimum of six permit judges.
- For entries greater than 2,000 dogs, use a minimum of eight permit judges.

Newly approved permit judges are published monthly in the [Secretary's Page](#) of the [AKC Gazette](#), and listed in italics in the [Judges Directory](#) published annually in January. The [Secretary's Page](#) of the [AKC Gazette](#) (which lists newly approved permit judges), as well as the annual [Judges Directory](#), are also accessible from the AKC's web site at [www.akc.org/judges\\_directory/](http://www.akc.org/judges_directory/). The online [Judges Directory](#) includes permit judges and is updated monthly.

## Visiting Judges

The club must submit the request to the AKC's Judging Operations Department, **at least six months before the date of the closing**, for approval of a Visiting (foreign) Judge who has not previously judged in the United States.<sup>2</sup>

Requests must include the name and address of the judge, and the exact assignment. The individual must be an approved judge for the requested breeds, and in good standing, in his or her country.

Make it clear to the Visiting Judge that the assignment is subject to AKC approval.

For a judge who is not fluent in English, a translator must be available.

A Visiting Judge's all-breed assignments are limited to a total of eight all-breed shows annually.<sup>2</sup> There is no limitation on single-breed independent specialty assignments.

If you have questions about Visiting Judges, including eligibility, contact the AKC's Judging Operations Department.

---

<sup>2</sup> [AKC Board Policy, February 2006](#)

---

## Judges' Assignments

Judges accepting assignments must be available for the entire advertised hours of an event.

### Travel

Judges should not accept assignments for events on the same weekend if they are a great distance apart.<sup>3</sup> The Rules, Policies and Guidelines for Conformation Dog Show Judges,<sup>4</sup> states that "judges cannot do their best work if they are tired from travel. They should not accept assignments on succeeding days where more than a few hours travel by ground transportation is involved."

### Assignment Limitations

A conformation judge will not be approved to judge more than 175 entries per day, not including Group or Best in Show assignments. A specialty judge may be assigned a maximum of 200 entries. When the specialty is part of an all-breed event, the maximum of 200 entries applies only if no other breed, Group or Best in Show judging is assigned to the judge that day.<sup>5</sup>

Obedience judge limitations can be found in the Obedience/Rally Trial Manual or in the Obedience Regulations.<sup>6</sup>

**It is strongly recommended that judges who are assigned Group(s) judging *not* be given more than a 150-dog breed assignment or any special attractions (such as Puppy or Veterans Groups).**

Clubs can estimate their entry based on previous entries, taking into consideration such factors as specialties and supported entries. Other events held in conjunction with a show, e.g. obedience, agility and special attractions, may increase entries.

A club holding its first event should examine the entries of other clubs within a 100-mile radius. The day of the week that an event is held should also be considered; weekday events generally draw fewer dogs than weekend events.

Project the total entry as:

Estimated entry = Total entry of other club ± 10%

---

<sup>3</sup> Rules, Policies, and Guidelines for Conformation Dog Show Judges, p.6

<sup>4</sup> Rules, Policies and Guidelines for Conformation Dog Show Judges, p.6

<sup>5</sup> Rules Applying to Dog Shows, Chapter 7, Section 13

<sup>6</sup> Obedience Regulations, Chapter 1, Section 26

Divide the estimated entry as follows:

Sporting.....	22%
Hounds.....	16%
Working .....	20%
Terriers .....	9%
Toys.....	9%
Non-Sporting.....	12%
Herding.....	12%

## Division of a Breed Assignment

If more than one judge is to be used at an independent or designated specialty, the assignments must follow these guidelines:<sup>7</sup>

In breeds that have varieties, assignments may be divided by variety, with one of the judges designated as the Best of Breed and Inter-Variety judge.

In breeds that have no varieties, the assignments may be divided by sex:

- When there are two judges, all dog classes should be judged by one judge, and all bitch classes judged by the other judge. Any competition not divided by sex may be assigned to either of the two judges.
- When there are three judges, all dog classes should be judged by one judge, and all bitch classes judged by the second judge. Any competition not divided by sex should be judged by the third judge.

## Judging Conflicts

Judging assignments are regulated by the following AKC policies.

### Breed Judging

A judge will not be approved to judge the same breed, Group or Best in Show at two shows held within 30 days and 200 straight-line miles of each other.<sup>8</sup>

The 30-day limitation is calculated by the **first day of the show being counted as day one**—judge may **judge on the 31<sup>st</sup> day**. There are no such restrictions on non-regular classes or Special Attractions. Two judges who are approved to judge dogs and bitches at back-to-back specialty or specialties will be allowed to exchange assignments on the second day.

---

<sup>7</sup> Rules Applying to Dog Shows, Chapter 6, Section 5

<sup>8</sup> Rules, Policies, and Guidelines for Conformation Dog Show Judges, p.5

The AKC's Event Operations Department will check for conflicts. If you have questions about whether an assignment may or may not exceed the 200-mile limit, contact the Event Operations Department.

A judge will not be approved to judge the breed, the Variety Group of which the breed is a part, and Best in Show at the same event. An exception may be made in hardship cases for a specific event.<sup>9</sup>

Any restrictions beyond the 30-day/200-mile limits are between the club and the judge, and should be included in the contract.

---

## Finances

Finances must be considered when preparing a judges panel. A percentage of the event budget must be devoted to the panel. To reduce overhead, a club may share judges' expenses with other events.

## Contracts

If an arrangement is made between two or more clubs and a judge, each party involved must understand its responsibility to the judge, and what assignment will be performed at each event. All agreements between clubs are the responsibility of each club.

Get a definite commitment from each judge for the total charges. Contracts should clearly define all expenses and fees. These arrangements must be in writing in the form of a signed contract.

The club should keep accurate records of any verbal or written contracts with judges. If the club's leadership changes, these records will help the new leadership to ensure that judges' contracts are honored.

## Cost Estimation

Total the cost for each judge. Consider lodging while at the event, transportation, out-of-pocket expenses such as meals, and the judge's fee.

Calculate the approximate number of dogs a judge may be expected to draw. Divide the total cost of all judges by the estimated number of dogs to get a per-dog cost.

---

<sup>9</sup> Rules Applying to Dog Shows, Chapter 7, Section 19; Rules, Policies, and Guidelines for Conformation Dog Show Judges, p.5



---

## Communications with Judges

When confirming judging assignments, certain procedures should be followed:

Draw up a tentative judging slate after consulting the AKC Judges Directory or the Judges Directory on the AKC's web page to confirm the judge's eligibility to judge the breeds to be assigned.

Contact the judge to ascertain initial availability, fees and projected expenses. See the example Judging Availability Inquiry Letter, p. 13-57. Telephone is usually the quickest method.

Write promptly to the judges you have selected, enumerating the following, enclosing two copies of the contract. See the example Judge's Contract, p. 13-59. One copy of the contract must be signed and returned to you containing the following information:

- Name of the club
- Name, address and telephone and fax number(s) of the club and the contact person. Emergency contact number should the judge need to contact club the day of the event.
- Date and location of the event, and whether the event is indoors or outdoors.
- The airport the judge will be flying into and out of.
- List of the specific judging assignments being submitted to the AKC.<sup>10</sup> It is important that breed, Group and Best in Show assignments be double-checked and listed correctly in the contract.
- Fee plus projected expenses. If sharing a judge with another club(s), it is important to state what percentage each club is responsible for. When referring to expenses, be as specific as possible, e.g. number of nights in a hotel, level of airline fare, and ground transportation.
- Notification of filming if the event will be videotaped.<sup>11</sup>
- Notification of accommodations and hospitality arrangements. Include details such as the name of the hotel/motel, directions to the hotel/motel, directions to the event site, the hotel's dining features, hotel telephone numbers and hotel emergency number. Brochures provided by hotels or motels include most of the necessary information about the facilities. If this information is not available at the time the contract is prepared, or is not yet finalized, this information should be sent to judges as soon as it is available.

---

<sup>10</sup> Rules Applying to Dog Shows Chapter 4, Section 1

<sup>11</sup> AKC Board Policy, July 1998

- A date by which the judge must return the written confirmation of acceptance of the assignment.

Inform the judges about the hospitality arrangements. See Hospitality: Judges Information Sheet, p. 13-60.

Two copies of the hospitality information should be sent to the judge. One copy should be retained by the judge; the other copy should be signed by the judge and returned to the club.

---

## Club's Responsibility to the Judge

All assignments **must** be promptly confirmed in writing.<sup>12</sup> See the example Judging Confirmation Letter, p. 13-58. The written confirmation should include the specific breed, group and obedience class(es). **No change in a judge's assignment may be made unless the judge agrees to the change. All changes must be in writing.**<sup>13</sup>

The club usually makes all arrangements for the judge's lodging, meals, and travel, to and from the event site and airport, unless there is agreement to do otherwise.

---

## Judge's Responsibility to the Club

Judges should reply promptly when invited to judge.

Judges **must** keep accurate records concerning dates and assignments.<sup>14</sup>

A judge who is uncertain if a conflict exists should check with the AKC's Event Operations Department **before** accepting any assignment.

A judge is responsible for contractual restrictions beyond the 30-day/200-mile limit.

When accepting an invitation, judges should provide fee and total anticipated expenses, if requested.

If a judge cannot fulfill an assignment, the club must be notified immediately.<sup>15</sup>

A judge delayed in transit should make every effort to contact the Show Chair, superintendent, or show secretary.

**When a judge signs a dated contract, provided by the club, the judge and the club are responsible for abiding by its conditions.**<sup>16</sup>

---

<sup>12</sup> Rules, Policies, and Guidelines for Conformation Dog Show Judges, p.5

<sup>13</sup> Rules Applying to Dog Shows, Chapter 7, Section 7

<sup>14</sup> Rules, Policies, and Guidelines for Conformation Dog Show Judges, p.5

<sup>15</sup> Rules, Policies, and Guidelines for Conformation Dog Show Judges, p.7

<sup>16</sup> Rules, Policies, and Guidelines for Conformation Dog Show Judges, p.6



## 7: Scheduling Judging

<b>Setting up the Schedule</b> .....	<b>7-2</b>
Starting Time for Judging .....	7-2
Scheduling Rings .....	7-2
Scheduling Breed Judging .....	7-3
Scheduling Breed Judging at National Specialities ..	7-3
Scheduling Lunch and Breaks .....	7-4
Scheduling Group and Best in Show Judging .....	7-4
Scheduling Obedience Judging .....	7-4
Scheduling Junior Showmanship Judging .....	7-5
<b>Judging Changes</b> .....	<b>7-5</b>
Judging Program Not Mailed .....	7-5
Judge Changes and Refunds .....	7-5
Judging Program Already Mailed .....	7-6
Emergency Change of Judge .....	7-6
Overloads .....	7-6
Breed Judges .....	7-6
Obedience Judges .....	7-7
Notification of a Judging Change .....	7-8
Breed Overload Example .....	7-8
Obedience Overload Example .....	7-8
Breed and Obedience Overload Example .....	7-9

---

## Setting up the Schedule

Scheduling judging is not a simple task. Scheduling is usually done by the club's superintendent or show secretary.

### Starting Time for Judging

An official starting time must be announced.<sup>1</sup> The start time of an event may vary depending on circumstances. Events may begin early to accommodate very large entries, or later when the number of entries is smaller.

The event should end as early as possible because exhibitors and judges like to travel to the next event or to start home at a reasonable hour. Most events should be scheduled to end by 6:00 p.m. Expedite group judging by using a separate area for photographs. Clubs must conclude judging by the posted closing time.<sup>2</sup> For outdoor events, ensure that judging will be completed before sunset.

Scheduling procedures that can help conclude an event earlier are:

- Schedule start time for judging on or before 9 a.m.
- Add additional rings and obtain additional judges.
- Assign group judges no more than 125-150 class dogs.
- Schedule two groups at a time. Stagger the starting time by fifteen minutes.

### Scheduling Rings

Assigned rings must be large enough to accommodate the largest breed being judged or the class with the largest number of entries.

Arrange the schedule so that a judge can complete his assignment in one ring whenever possible. If a judge must move from a large ring to a small ring to accommodate different size breeds, dogs of similar size should be scheduled in the same block of time. When a judge is scheduled in more than one ring, schedule that judge in rings that are as close to each other as possible.

Within a judging assignment, all breeds judged on a table should be scheduled consecutively, and all breeds judged on a ramp should be scheduled consecutively.

Any rings that are to be combined and used for group judging should be scheduled so that they are available well before the group judging is to begin.

---

<sup>1</sup> Rules Applying to Dog Shows, Chapter 6, Section 2; Chapter 7, Section 12

<sup>2</sup> Rules Applying to Dog Shows, Chapter 6, Section 2

## Scheduling Breed Judging

Consider the welfare of the dogs when scheduling. For example, schedule short-nosed breeds in the cooler part of the day.

The judging schedule must be based on each judge judging about 25 dogs per hour<sup>3</sup> (2.4 minutes per dog). Permit, Sweepstakes or Futurity judges usually judge at a slower rate than experienced judges do. A minimum judging rate of about 20 dogs per hour (3 minutes per dog) is appropriate for these judges and they should be scheduled accordingly. Since the AKC Executive Field Representative frequently observes permit judges, every attempt should be made to schedule these assignments at non-conflicting times. To estimate breed judging start/stop times, a club may request judges to indicate their usual judging rate.

Each judge's breed and variety assignments must be divided into periods of about one hour, except in cases where the entry in a breed or variety exceeds 30.<sup>4</sup>

If the total number of entries assigned to any judge exceeds 175, assign another judge to some of the breeds for the overloaded judge. The club must contact a judge for permission to assign him/her additional breeds. Breeds can only be reassigned to another judge who is approved by the AKC to judge that breed.<sup>5</sup>

Group judges who also have breed assignments should be scheduled so that they can complete their breed assignments before group judging begins. The AKC recommends that clubs assign approximately 125 dogs, but no more than 150 dogs, to at least two of their group judges.

If judges are assigned breeds in more than one group, organize their breed-judging schedule by group.

### Scheduling Breed Judging at National Specialties

Due to the number of dogs entered in an individual class at national specialties, the Breed classes are sometimes split. Therefore, an exhibitor may make a protest by asking the steward to inform the judge about the protest, at which point the judge should personally speak with the protesting exhibitor. Exhibitors should not be prevented from protesting a dog if they are not actually in the ring at the same time as the dog being protested due to the split class, as long as the exhibitor is personally showing a dog in the same class.<sup>6</sup>

---

<sup>3</sup> Rules Applying to Dog Shows, Chapter 7, Section 12

<sup>4</sup> Rules Applying to Dog Shows, Chapter 7, Section 12

<sup>5</sup> Rules Applying to Dog Shows, Chapter 7, Section 8

<sup>6</sup> Field Representatives Policy Manual, House/More/Hayes – September 1999, pg. 12

## Scheduling Lunch and Breaks

Any conformation judge whose assignment exceeds five hours must be allowed forty-five minutes to one hour for rest or meals.<sup>7</sup> Obedience/Rally judges must be allowed forty-five minutes to one hour for meals or rest at their discretion.<sup>8</sup> Coordinate with the food service to ensure that lunch will be available at the time scheduled for lunch breaks.

Stagger lunch breaks to allow judges to resume their assignments on schedule. Judges with breed assignments that are small may be scheduled to use rings that will be vacant while another judge is at lunch.

At an all-breed event, breaks may be scheduled between breed assignments or scheduled at the discretion of judges. Special care must be taken when preparing the break schedule for a specialty event, particularly where there is a large entry (e.g., a national specialty). Try to schedule the lunch or rest break at a logical stopping point.

## Scheduling Group and Best in Show Judging

Decide in advance which rings are to be used for the groups. Judging in these rings must be completed before the groups are scheduled to begin. When scheduling breed assignments backward from group judging, the judging in the rings to be used for the groups must start early enough to avoid possible delays.

Judges having Group or Best in Show assignments must be scheduled to complete all their breed assignments before their scheduled group judging time. The AKC suggests that Best in Show be judged by someone who has not already judged any breed or group at that show.<sup>9</sup>

For an event to end by 6:00 p.m., group judging should start by 3:00 p.m. or earlier. Breed judging in at least two groups should be scheduled to be complete before group judging is scheduled to begin. Judging of all breeds within a group must be scheduled to be complete before that group's judging begins. The breeds in a particular group that are latest on the schedule should be scheduled in rings as close as possible to the rings intended for group judging.

## Scheduling Obedience Judging

When making up a judging schedule for obedience, try to avoid conflicts between classes, especially between the Open B and Utility B classes.

---

<sup>7</sup> Rules Applying to Dog Shows, Chapter 7, Section 12

<sup>8</sup> Obedience Regulations, Chapter 1, Section 26; Rally Regulations, Chapter 2, Section 2

<sup>9</sup> Rules Applying to Dog Shows, Chapter 7, Section 19

A club may use two or more judges for any obedience class.<sup>10</sup> When classes are divided between judges, the distribution of dogs between judges must be decided by drawing lots.<sup>11</sup>

## **Scheduling Junior Showmanship Judging**

The Junior Showmanship judges should be scheduled to judge 20 exhibitors per hour.<sup>12</sup>

---

## **Judging Changes**

A club may need to make a change in its judging panel after the premium list has been distributed and entries have closed because a judge has drawn more than 175 entries in breed or eight hours of judging in obedience. No change to a judge's assignment may be made unless the judge agrees to the change.<sup>13</sup>

### **Judging Program Not Mailed**

If the club knows any time prior to ten days before the first day of its event that an advertised judge will be unable to fulfill his assignment for any reason, a substitute judge must be hired and approved by the AKC. Notification of the change must be included in the judging program. Exhibitors affected by the judge change may withdraw their entries and receive a refund no later than thirty minutes prior to regular judging.<sup>14</sup>

### **Judge Changes and Refunds**

When there is a judging change in any class in the show, the exhibitor should get a refund for that class, however no refund will be given later than 30 minutes prior to the judging of any classes of the breed in question (this does not apply for Group or Best in Show judge changes).<sup>15</sup> No refund will be given for any Sweepstakes judging change. There is one caveat. Some Sweepstakes or Futurities do require entry in a regular class at the show in order to be eligible for the Sweepstakes or Futurity. If there is a judging change in the breed and the exhibitor cancels because of this judge change, they would no longer be entered in a regular class and thus would not be eligible for the Sweepstakes or Futurity.

In the case of a Futurity, any refund would be for the actual entry fee only, and not for all of the prior nomination and continuation fees.

---

<sup>10</sup> Obedience Regulations, Chapter 1, Sections 28, 29

<sup>11</sup> Obedience Regulations, Chapter 1, Section 29

<sup>12</sup> Rules, Policies and Guidelines for Conformation Dog Show Judges, page 10

<sup>13</sup> Rules Applying to Dog Shows, Chapter 7, Section 7

<sup>14</sup> Rules Applying to Dog Shows, Chapter 7, Section 8

<sup>15</sup> Rules Applying to Dog Shows, Chapter 7, Section 9

## Judging Program Already Mailed

When the superintendent or show secretary named in the premium list has received notice of a judge's withdrawal or cancellation prior to the opening day of the event, but after printing the judging program, exhibitors must withdraw anytime prior to the scheduled start of any regular class judging of that breed at the event.<sup>16</sup>

## Emergency Change of Judge

While it may not be possible to notify affected exhibitors of an emergency change of judge prior to the event, a notice of the change must be posted at the event.

## Overloads

The maximum number of entries in breed judging assigned to any judge in one day must not exceed 175, or 200 for an individual judging a specialty only. These numbers include Sweepstakes/Futurity, Obedience, and Rally entries.<sup>17</sup>

No obedience judge can be assigned to more than eight hours of judging as outlined in Obedience Regulations.<sup>18</sup>

The maximum for Rally judging is 22 entries per hour.<sup>19</sup>

If a judge's assignment exceeds these limits, enough of the assignment must be given to a substitute judge to eliminate the overload.<sup>20, 21</sup> To select a judge to substitute, consider prospective judges in this order:

- A judge, on the panel or otherwise available, approved for the breed(s)/group/ class (es).

In an emergency:<sup>22</sup>

- A judge approved for breeds in that group.
- Any approved judge.
- In a real emergency, anyone in good standing.

## Breed Judges

- **If a judge is assigned only one breed**, and if the entry in that breed exceeds 200 for the day, the assignment must be reduced first by reassigning to another judge enough non-regular classes or Junior Showmanship to eliminate the overload.

---

<sup>16</sup> Rules Applying to Dog Shows, Chapter 7, Section 9

<sup>17</sup> Rules Applying to Dog Shows, Chapter 7, Section 13

<sup>18</sup> Obedience Regulations, Chapter 1, Section 26

<sup>19</sup> Rally Regulations, Chapter 2, Section 2

<sup>20</sup> Obedience Regulations, Chapter 1, Section 28

<sup>21</sup> Rules Applying to Dog Shows, Chapter 7, Section 13

<sup>22</sup> Rules Applying to Dog Shows, Chapter 7, Section 4



If the judge's assignment still exceeds 200, one or more of the regular classes should be reassigned to another judge until the original judge's assignment is brought as closely as possible within the prescribed limit. Junior Showmanship should be reassigned before any breed classes are reassigned, then the class having the smallest number of dogs or the class requiring the least time should be reassigned.

- **If a judge is assigned four or fewer breeds**, the assignment must be reduced first by reassigning to another judge enough classes from one breed to eliminate the overload, with any non-regular classes being removed first. Junior Showmanship should be reassigned before any breed classes are reassigned. If it is necessary to remove regular classes, the class having the smallest number of dogs or the class requiring the least time should be reassigned.<sup>23</sup>
- The same procedure should be followed for as many breeds as necessary until the overload is eliminated. This will apply whether or not the breed in question has varieties.

To assist clubs with overloads, the Event Operations Department will check to determine if particular judges are available for a specific date. This department will also provide you a list of available judges by state to assist in completing the panel.

## **Obedience Judges**

Any non-regular classes must be removed first. If it is necessary to remove regular classes, the class having the smallest number of dogs or the class requiring the least time should be reassigned.

**If the overloaded judge is only assigned one class**, the entry in that class must be divided as evenly as possible between the advertised judge and the other judge by drawing lots.<sup>24</sup>

---

<sup>23</sup> Rules Applying to Dog Shows, Chapter 7, Section 13

<sup>24</sup> Obedience Regulations, Chapter 1, Section 28

## Notification of a Judging Change

There is standard wording to announce a change of judge in the judging program or at the show or trial. This wording should include an announcement of the change and a reference to the appropriate rule or regulation.

### Breed Overload Example

#### OFFICIAL NOTICE

#### CHANGE OF JUDGE

In accordance with Chapter 7, Section 13 of the *Rules Applying to Dog Shows*, due to the large entry, and with American Kennel Club approval, \_\_\_\_\_ will judge \_\_\_\_\_ (list the breed) in place of \_\_\_\_\_.

Or

In accordance with Chapter 7, Section 13 of the *Rules Applying to Dog Shows*, due to the large entry, and with American Kennel Club approval, the following changes apply:

<u>Breed</u>	<u>Original Judge</u>	<u>New Judge</u>
Lhasa Apso	Miss Allison Johnston	Miss Bri Tesarz
German Shepherd Dog	Miss Katie Peralta	Miss Whitney Meeks

### Obedience Overload Example

#### OFFICIAL NOTICE

#### CHANGE OF JUDGE

In accordance with Chapter 1, Section 28 of the *Obedience Regulations*, due to the large entry, and with American Kennel Club approval \_\_\_\_\_ will judge \_\_\_\_\_ (list the class) in place of \_\_\_\_\_.

Or

In accordance with Chapter 1, Section 28 of the *Obedience Regulations*, due to the large entry, and with American Kennel Club approval the following changes apply:

<u>Class</u>	<u>Original Judge</u>	<u>New Judge</u>
Novice A	Miss Emily Bisso	Dr. Adam King
Utility B	Miss Emma Stone	Miss Kimberly Silva

## Breed and Obedience Overload Example

### OFFICIAL NOTICE

### CHANGE OF JUDGE

In accordance with Chapter 7, Section 13 of the *Rules Applying to Dog Shows*, and with American Kennel Club approval \_\_\_\_\_ will judge (list the breed) in place of \_\_\_\_\_ and \_\_\_\_\_ will judge (list the obedience class) in place of \_\_\_\_\_.

Or

In accordance with Chapter 7, Section 13 of the *Rules Applying to Dog Shows*, and with American Kennel Club approval the following changes apply.

<u>Breed/Class</u>	<u>Original Judge</u>	<u>New Judge</u>
Akita	Miss Julia Nietsch	Mr. Michael Kennedy
Novice A	Miss Jamie Conway	Miss Stephanie Smith



# 8: Additional Classes and Special Attractions

<b>Obedience Trial Classes with a Show</b> _____	<b>8-2</b>
AKC® Rally.....	8-2
<b>The Miscellaneous Class</b> _____	<b>8-2</b>
<b>Junior Showmanship Classes</b> _____	<b>8-3</b>
<b>Specialty Clubs</b> _____	<b>8-3</b>
Designated Specialty .....	8-3
Supported Entry.....	8-4
Evening Specialties .....	8-5
Same Day Specialty Show.....	8-5
Concurrent Specialties.....	8-5
Sweepstakes or Futurity Classes.....	8-6
Veteran Sweepstakes.....	8-7
<b>Non-Regular Classes</b> _____	<b>8-7</b>
Single Dog Entries.....	8-8
Veterans Class.....	8-8
Field Trial Class.....	8-8
Multiple Dog Entries.....	8-8
Stud Dog Class .....	8-9
Brood Bitch Class.....	8-9
Brace Class .....	8-9
Team Class .....	8-9
<b>Special Attractions</b> _____	<b>8-10</b>
Best Puppy in Show, Best Veteran in Show & Best Bred- By-Exhibitor .....	8-10
AKC National Owner-Handed Series (NOHS) .....	8-11
Special Awards.....	8-11
Award of Merit for Superior Quality .....	8-11
Parade of Title Holders.....	8-12
Other Special Attractions.....	8-12

---

## Obedience Trial Classes with a Show

Any all-breed, limited breed or specialty club may be approved to hold obedience classes with its shows.<sup>1</sup> Contact the AKC's Club Relations Department concerning your club's eligibility.

### AKC Rally®

Clubs can attract new exhibitors by offering this competition, which emphasizes the usefulness of the purebred dog as a companion to man. The trials should produce dogs that behave in the home, public places and in the presence of other dogs at all times and under all conditions.

Any AKC club may be granted permission to hold a rally trial if, in the opinion of the AKC Board of Directors, it is qualified to do so, provided the club holds the event(s) for which it was originally formed at least once every two years.<sup>2</sup>

Descriptions of the exercises, rally signs and applications may be viewed or downloaded from the AKC web site.

Further information about AKC Rally and Obedience classes can be found in the [Obedience/Rally Trial Manual](#).

---

## The Miscellaneous Class<sup>3</sup>

Any all-breed or group club awarding championship points at their event must offer classes for the Miscellaneous Class breeds (or those breeds that will become eligible for their group) at the event.

**Section 22.** The Miscellaneous Class shall be for purebred dogs of such breed as may be designated by the AKC® Board of Directors. No dog shall be eligible for entry in the Miscellaneous Class unless the owner has been granted an AKC identification number, and unless the AKC identification number is given on the entry form. Application for an AKC identification number shall be made on a form provided by the AKC and when submitted must be accompanied by a fee set by the Board of Directors.

The regular Miscellaneous Classes for each breed shall be Puppy, Bred-by Exhibitor and Open, with the same eligibility requirements in Sections 4, 8 and 10 of this Chapter respectively. These classes shall be divided by sex. All class winners

---

<sup>1</sup> [Obedience Regulations](#), Chapter 1, Section 2

<sup>2</sup> [AKC Rally Regulations](#), Chapter 1, Section 1

<sup>3</sup> [Rules Applying to Dog Shows](#), Chapter 3, Section 22

within a breed shall compete for Best of Breed and Best of Opposite Sex to Best of Breed.

Each of the Miscellaneous Class Best of Breed winners shall be eligible to compete for Best in Miscellaneous Class. All entries for Best in Miscellaneous Class shall be made after judging of the individual Miscellaneous breed classes and no entry fee shall be charged. In the event that the owner of a dog designated Best of Breed shall not exhibit the dog in the Best of Miscellaneous Class Competition, no other dog of the same breed shall be allowed to compete. There shall be no further competition for dogs entered in the Miscellaneous Class.

The ribbons shall conform to Chapter 5, Section 2 of these rules and shall be the following colors:

- First Prize - Rose
- Second Prize - Brown
- Third Prize - Light Green
- Fourth Prize - Gray
- Best of Breed - Orange
- Best of Opposite - Lavender
- Best in Miscellaneous - Pink and Green

---

## Junior Showmanship Classes

The requirements for Junior Showmanship are detailed in the Conformation Junior Showmanship Regulations, Guidelines for Judging Juniors in Conformation, Juniors in Performance Events.

---

## Specialty Clubs

A specialty club that is sanctioned by AKC and has held at least one successful B-Level sanctioned match may host a specialty for the parent club.

The proper notice in the premium list and catalog is:

This \_\_\_\_\_ Club Specialty is hosted by the \_\_\_\_\_ Club.

No listing of officers or other details of the hosting club is permitted.

Non-licensed/non-sanctioned clubs may not host an AKC licensed show and may only be listed in a catalog as a supporter or contributor, or to be recognized for trophy donations.

## Designated Specialty

Where a specialty club wishes to consider as its Specialty Show the breed classes at an all-breed show, the AKC will approve the “considering of classes” if the following conditions are satisfied:<sup>4</sup>

- An application is submitted by the specialty club.
- A license fee of \$15.00 is paid.
- The breed’s parent club has consented in writing to the specialty club’s holding the show.
- The location of the event and the superintendent/show secretary are the same as for the all-breed club’s event.

A breed in which there are varieties for show purposes must consider the classes in all varieties as its specialty show. For example, a Collie club cannot consider the classes only for Rough Collies, but must include Smooth Collies; a Poodle club must consider the classes in all three varieties.

The proper notice, in the all-breed club’s premium list and catalog, for a specialty club that is designating the classes at the all-breed show as its specialty show is:

The \_\_\_\_\_ Club will consider the \_\_\_(breed)\_\_\_ classes at the show as its specialty show.

The name of the specialty judge may be inserted in the notice.

The names of the specialty club’s officers and the address of the club’s secretary must be listed following this notice.<sup>5</sup> Listing of the specialty club’s board members or governors is optional.

Listing of the specialty club’s committees or naming of the specialty club’s officials is not permitted.

Any trophies allowed at an independent specialty, such as those awarded on a three-time win basis, may be offered at a designated specialty.<sup>6</sup>

## Supported Entry

A specialty club that is sanctioned by the AKC, and which has held at least one successful B-Level sanctioned match, may support the entry of its breed at an all-breed or group club event. Supported entries are limited to one specialty club per breed.

No application is required for a supported entry, and supported entries are automatically approved if they are held at an all-breed event. However, a specialty club can only support an entry if the hosting all-breed club first approves. An

---

<sup>4</sup> Rules Applying to Dog Shows, Chapter 2, Section 13

<sup>5</sup> Rules Applying to Dog Shows, Chapter 6, Section 1

<sup>6</sup> Rules Applying to Dog Shows, Chapter 5, Section 8

application must be submitted if the specialty club wishes to hold a sweepstakes or futurity event as part of the supported entry. Only AKC licensed or sanctioned clubs may hold sweepstakes events. Clubs that are not licensed or sanctioned with the AKC can only provide the trophies for supported entries and cannot provide for any class that the hosting all-breed show is not holding. The only place that a club not licensed or sanctioned with the AKC can be listed is in the trophy section of the premium list

The proper notice for the premium list and catalog is:

The \_\_\_\_\_ Club will support the entry of \_\_\_\_\_ (breed) \_\_\_\_\_ at this show.

No listing of officers or other details concerning the specialty club are permitted.

The specialty club should reach an agreement with the all-breed or group club about additional details such as trophies, parking, judge selection, and time of judging.

If a specialty club wishes to support an entry at an all-breed or group club show outside its assigned area and in the area of another specialty club of the same breed, it should notify the other specialty club and receive their permission.

## Evening Specialties

An Evening Specialty must be held at the same site and on the same day as an all-breed show held earlier in the day. It must start at least 30 minutes after the all-breed's Best in Show competition is finished and may have no more than 50 entries. Sweepstakes, special attractions, or matches will not be approved in conjunction with evening events.<sup>7</sup>

For a club to hold an evening specialty, it must obtain written consent from the all-breed club. A copy of the all-breed club's letter must be submitted to the AKC with the show application.

More than one specialty club may hold an Evening Specialty on the site, and these events may be judged concurrently. Only one specialty per breed may be held as an evening specialty.

The all-breed club is not required to give up the breed at its show.

## Same Day Specialty Shows

Two independent specialty shows for the same breed may be held on the same day at the same site. Each event is limited to no more than 100 entries, inclusive of sweepstakes, special attractions, or matches.<sup>8</sup>

## Concurrent Specialties<sup>9</sup>

Specialty clubs can hold an independent specialty show concurrently with an all-breed show with the following limitations:

---

<sup>7</sup> [AKC Board Policy, December 2005](#)

<sup>8</sup> [AKC Board Policy, December 2005](#)

<sup>9</sup> [AKC Board Policy, August 2011](#)



1. The specialty club must obtain permission from the all-breed club in order to apply.
2. The maximum number of independent specialties will be determined by the Event Operations Staff, considering the adequacy of the all-breed show's facility.
3. The specialty must be held on the same grounds as the concurrent all-breed show (i.e. the same physical address).
4. The entry on the Specialty breed(s) is limited to 100 entries in both the specialty & all-breed club events.
5. The ownership of the corresponding date must be agreed upon in writing prior to event approval.
6. The all-breed class must be held prior to the independent specialty in order to accommodate the Group judging.
7. Evening specialties will be permitted for breeds that are not holding concurrent specialties with the all-breed show.

### **Sweepstakes or Futurity Classes**

A specialty club which has been approved by the AKC to hold sweepstakes and futurities may hold these events in conjunction with its event or with an all-breed event. The following conditions must be met:

- An application is submitted by the specialty club.<sup>10</sup>
- Entries for sweepstakes or futurity are only accepted for dogs that are at least six months of age.
- The class divisions are specified in the premium list. Age divisions are determined by the specialty club. Classes must be divided by sex.
- All other qualifications for the dogs and handlers may be set by the specialty club and **must** be stated in the premium list.
- The club may not retain for expenses more than 35% of the sweepstakes entry fees collected.

No sweepstakes or futurity judge, or any person residing in the judge's household is permitted to exhibit or act as agent at the event. No dog owned by this judge or any member of the judge's household is eligible to be entered at the event. These rules apply to sweepstakes and futurities judges as they do to those judging regular classes.<sup>11</sup>

When several specialty clubs hold their events as a combined specialty at the same site on the same date, each of the specialties is considered a separate event for the purpose of applying AKC rules. The judge of the sweepstakes or futurity may not exhibit on the day(s) they judge. A multi-day specialty is considered one event, and the restriction will apply for the duration of the event.<sup>12</sup>

---

<sup>10</sup> Rules Applying to Dog Shows, Chapter 2, Section 14

<sup>11</sup> Rules Applying to Dog Shows, Chapter 11, Section 13

<sup>12</sup> Rules, Policies and Guidelines for Conformation Dog Shows Judges, page 3

The colors of ribbons given in a sweepstakes or futurity are the same as those given at sanctioned matches:<sup>13</sup>

- First - Rose
- Second - Brown
- Third - Light Green
- Fourth - Gray
- Special prize – Green with pink edges
- Best of Breed – Orange
- Best of Variety – Orange & White
- Best in Match, Sweepstakes or Futurity – Pink and Green
- Best of Opposite Sex to Best in Match, Sweepstakes or Futurity – Lavender
- Best of Opposite Sex to Best in Variety in Sweepstakes or Futurity – Lavender & White

Three-time win trophies may not be offered in sweepstakes or futurities.<sup>14</sup>

## Veteran Sweepstakes

The sweepstakes will be open to the breed specified in the premium list, subject to the minimum age determined by the club.

A predetermined fee is usually required for entering, regardless of other classes entered, even though it is designated as an additional class. To enter, write “Veteran Sweepstakes” in the space for Dog Show Class or in the box for Additional Class, if appropriate.

The dog or bitch need not be entered in any other class at the show. Veterans competing in Sweepstakes only may be spayed or neutered only if it is stated in the premium list that this is acceptable.

Judging of veteran sweepstakes will take place at a time determined by the club. Trophies or prizes may be awarded as determined by the club.

---

## Non-Regular Classes

Clubs have the prerogative of establishing additional non-regular classes.<sup>15</sup> The requirements for eligibility must be established and stated in the premium list. The AKC must approve the eligibility requirements for any non-regular classes before they appear in the premium list.

Ribbons may be offered for four places or for first place only and must be listed in the premium list.<sup>16</sup>

Non-regular classes may be single-dog-entry (only one dog is judged) or multiple-dog-entry (two or more dogs are judged together as a unit). The winners

---

<sup>13</sup> [Rules Applying to Dog Shows](#), Chapter 5, Section 3

<sup>14</sup> [American Kennel Club Policy Manual](#), Section 4, Paragraph IV.C.2

<sup>15</sup> [Rules Applying to Dog Shows](#), Chapter 3, Section 13

<sup>16</sup> [American Kennel Club Policy Manual](#), Section 4, Paragraph IV.A

of single-dog-entry classes, if otherwise undefeated in the show, compete for Best of Breed/Variety;<sup>17</sup> the winners of multiple-dog-entry classes do not.

## Single Dog Entries

**All Non-Regular Classes for single-dog entries at independent and designated specialties may be scheduled at any time before Best of Breed or Variety.<sup>18</sup>**

**These classes must be divided by sex.**

The most common non-regular single-dog-entry breed classes are:

### Veterans Class

The Veterans class is for dogs and bitches who meet a minimum age requirement set by the club. The class may be split further into age divisions. If the class is split, each first place winner is eligible to compete for Best of Breed.

### Field Trial Class

The Field Trial class is for dogs and bitches that have placed in an AKC licensed or member field trial or have a Field Trial title (criteria must be printed in the premium list). In certain breeds, having Field Trial Judges Awards of Merit or parent club field titles may be included in the eligibility requirements.

## Multiple Dog Entries

All dogs making up the multiple-dog entry must be shown together as a unit, but an [official AKC entry form](#)<sup>19</sup> must be completed for each dog making up the entry. Specify the non-regular class in the Additional Classes section of the entry form if the dog is entered individually in one of the regular classes, Best of Breed or Variety competition, or some non-regular class other than the multiple-dog-entry class.

The premium list should state whether each dog entered for the unit will be charged a fee for entering this class, or whether one fee for the unit will be charged.

Classes for multiple-dog entries may be judged at any time.<sup>20</sup>

Because the judge's decision in multiple-entry classes is based on the merits of more than one dog or bitch, no one of the dogs or bitches making up the unit will be eligible to compete for Best of Breed or Variety by virtue of having won this class.

The most common non-regular multiple-dog-entry breed classes are:

---

<sup>17</sup> [Rules Applying to Dog Shows](#), Chapter 3, Section 14

<sup>18</sup> [American Kennel Club Policy Manual](#), Section 4, Paragraph II.1(revised April 1999 Board meeting)

<sup>19</sup> Form may be downloaded from the AKC web site

<sup>20</sup> [American Kennel Club Policy Manual](#), Section 4, Paragraph II.2

## Stud Dog Class

The Stud Dog class is for stud dogs and two or more of their get.

## Brood Bitch Class

The Brood Bitch class is for brood bitches and two or more of their produce.

**The following applies to both Stud Dog and Brood Bitch classes:**

- **The club may permit more than the customary two offspring to be shown;** however, an upper limit to the number of offspring must be stated in the premium list.
- Offspring must be intact
- The owner of the sire or dam need not be the owner of the offspring.
- The offspring only are judged on their merit.
- A castrated male may be entered as Stud Dog in the Stud Dog class, and a spayed bitch may be entered as Brood Bitch in the Brood Bitch class.<sup>21</sup>
- The handler of each dog must wear a numbered armband.<sup>22</sup>

## Brace Class<sup>23</sup>

The Brace class is for two dogs of the same breed, both dogs are intact, and having one common owner listed on each dog. (Effective January 1, 2005)

The dogs comprising the brace must be named at the time of entry. Full particulars must be given for each dog on an individual entry form.

If a dog that is to be part of a brace is entered in another class and entered as part of a brace, specify "Brace Class" in the Additional Classes section of the form. If a dog is not entered in another class, specify "Brace Class Only" in the Dog Show Class section of the form.

## Team Class<sup>24</sup>

The Team class is for four dogs of the same breed, having one common owner listed on each dog. (Effective January 1, 2005)

The dogs comprising the team must be named at the time of entry. Full particulars must be given for each dog on an individual entry form.

---

<sup>21</sup> Rules Applying to Dog Shows, Chapter 11, Section 8

<sup>22</sup> Rules Applying to Dog Shows, Chapter 14, Section 2

<sup>23</sup> Rules Applying to Dog Shows, Chapter 3, Sections 17, 18

<sup>24</sup> Rules Applying to Dog Shows, Chapter 3, Sections 19, 20

If a dog that is to be part of a team is entered in another class and entered as part of a team, specify “Team Class” in the Additional Classes section of the form. If a dog is not entered in another class, specify “Team Class Only” in the Dog Show Class section of the form.

---

## Special Attractions

A club may engage dogs not entered in its event as a special attraction if the AKC gives its written approval.<sup>25</sup> The club’s written request for AKC approval must give details of the nature of the special attraction. If purebred dogs other than those eligible for AKC registration are to be included, a list of the breeds must be provided with the request. The [Special Attractions](#) form<sup>26</sup> should be completed and returned to the Event Operations Department.

The event must be restricted to dogs that are at least six months of age.

Any special attraction that involves a demonstration conducted by an official law enforcement agency or by a branch of the armed forces is acceptable.<sup>27</sup>

*The judging of a special attraction must not interfere with the orderly conduct of regular or group judging at the event. Best in Show judging may not be delayed more than 15 minutes for a Special Attraction judging. Whenever possible it should be held during a break in the regular judging, or in an area far enough removed from the judging ring(s) so it does not disturb the participants in the event. Special Attraction Groups may be judged prior to regular Group judging. Special Attractions that would cause undue delay may be held after Best in Show judging.*

Health services or booths are not special attractions and do not need approval for inclusion in the premium list. These include, but are not limited to clinics for heart, eye, thyroid, Von Willebrand’s, frozen semen collection, microchips, tattoos, or anything related to the general health and well-being of dogs.

### Best Puppy in Show, Best Veteran in Show & Best Bred By Exhibitor

- *Recommended practice for holding a Best Puppy in Show competition at all-breed shows is similar to that for Best Veteran and Best Bred by Exhibitor in Show competition.*
- *Best Puppy may be staged in any area of the site, as long as it does not interfere with the orderly conduct of judging at the show.*
- *Classes should be for puppy's 6-9 and 9-12 months old, but not 12-18 months old. The AKC does not consider a dog over 12 months of age to be a puppy.*

---

<sup>25</sup> Rules Applying to Dog Shows, Chapter 11, Section 10

<sup>26</sup> Form may be downloaded from the AKC web site

<sup>27</sup> AKC Board Policy, November 2002

- *Puppy Group and Best Puppy in Show judges need not be AKC-approved judges, and does not need to follow Regular Best in Show Judging.*
- *To facilitate smooth running of the Puppy Group judging, a time, ring number or specific location, and group order should be published in the judging program.*
- *It is important that normal judging procedures apply; i.e., only dogs not defeated in a puppy class are eligible for Best Puppy competition. Therefore, if the winner of a puppy class is not present for Best Puppy, a second-place dog may not compete in its place. Puppies must have been entered and shown in a Puppy Class; puppies moved up to Best of Breed competition are not eligible for Best Puppy. As in all regular classes, armbands must be checked to ensure that the correct dogs are competing in these special attractions.*
- *The judging of a special attraction must not interfere with the orderly conduct of regular or group judging at the event. Best in Show judging may not be delayed more than 15 minutes for a Special Attraction judging. Whenever possible it should be held during a break in the regular judging, or in an area far enough removed from the judging ring(s) so it does not disturb the participants in the event.*

## **AKC National Owner-Handled Series (NOHS)**

The AKC National Owner-Handled Series is a celebration of the dedication and enthusiasm of owner-handlers and is open to purebred dogs that are at least six months of age. Dogs must be marked as eligible to participate prior to the closing of entries. The judging of the NOHS is conducted following Best of Breed judging in each breed ring. For complete information regarding the judging, execution, and best practices for offering NOHS at your event visit the AKC NOHS [homepage](http://classic.akc.org/ohs/index.cfm) (<http://classic.akc.org/ohs/index.cfm>).

## **Special Awards**

The club may make awards in addition to those regularly offered. The qualifications for these awards must be stated in the premium list and catalog. The ribbons/rosettes for special awards are to be dark green.<sup>28</sup>

## **Awards of Merit for Superior Quality**

In addition to Best of Breed and Best of Opposite Sex to Best of Breed, a predetermined number of individual specimens may be awarded a special trophy or rosette in recognition of their merit.

The club may determine its own criteria for and the number of trophies or rosettes to be awarded.

---

<sup>28</sup> Rules Applying to Dog Shows, Chapter 5, Section 1

## **Parade of Title Holders**

The club established eligibility requirements and entry fees must be printed in the premium list. Dogs that are AKC titleholders of record may be entered in the parade. The special attraction must be specified on the entry form. Please note that the Parade of Title Holders is for AKC titleholders only.

All AKC titles must be shown on the entry form. Dogs entered in this class need not be entered in any other class at the event.

Dogs entered are usually presented with a rosette imprinted with the dog's name and title.

The parade is usually held at the conclusion of all judging, but may take place at any time.

## **Other Special Attractions**

Other special attractions may include, but are not limited to, classes for Exhibition Only, ATTS, and Temperament Testing. The club established eligibility requirements and entry fees must be printed in the premium list. The special attraction must be specified on the entry form. Non-AKC events may be offered with prior AKC approval.



# AKC Show/Trial Manual

## 9: Event Publications

Event Number .....	9-2
<b>Premium List</b> .....	<b>9-2</b>
Required Information for Premium List .....	9-3
Recommended Information for Premium List .....	9-4
<b>Judging Program</b> .....	<b>9-5</b>
Required Information for Judging Program .....	9-5
Recommended Information for Judging Program .....	9-7
Event Information .....	9-7
Ring Assignments .....	9-7
Directions .....	9-7
Event Site Layout .....	9-8
Overnight Parking Information .....	9-8
Material Mailed with the Judging Program .....	9-8
<b>Catalog</b> .....	<b>9-8</b>
Required Information for Catalog .....	9-9
Recommended Information for Catalog .....	9-10



The AKC requires the event-giving club to prepare a premium list, a judging program and a catalog for the event. Previous event publications can be helpful references for preparing these publications.

## Event Number

A club's event number may be printed on the cover and title pages of its event publications, and should be referenced on all correspondence concerning the event.

Event numbers can be found on the computer-generated approval notices from the AKC. The number is comprised of the following:

- the first four digits refer to the year of the event.
- the next four digits are the club number.
- the last two digits are a system-generated sequence number.

Because the event sequence number is system-generated, **it may not be the same for the corresponding event held in the following year.**

---

## Premium List

The premium list is the official announcement of a club's event, and the document on which most exhibitors base their entries. It is the contract between a club and the prospective exhibitors. The AKC has rules and policies concerning what may and what may not appear in the document.

Clubs holding back-to-back events or clustered events may use a combined premium list for all of the events being held together, provided that they use the same superintendent or show secretary. Individual clubs holding single or consecutive days of competition may combine their premium list. The premium list can be designated as the official premium list for all or some of the AKC events contained within it. For any event information for which it is not the official premium list a disclaimer prior to the event information must be included. The disclaimer must designate that the information is unofficial and must identify the secretary/superintendent responsible for the content.<sup>1</sup>

Four copies of the premium list **must** be sent to the AKC's Event Operations Department at the time it is sent to exhibitors.<sup>2</sup>

---

<sup>1</sup> [AKC Board Policy, July 2013](#)

<sup>2</sup> [Rules Applying to Dog Shows, Chapter 4, Section 2](#)

## Required Information for Premium List<sup>3</sup>

- The AKC Secretary's certification that permission has been granted for the club to hold the event, along with the AKC logo.
- The words "Licensed Show" when the event-giving club is not a member of the AKC.
- The date or dates of the event, its exact location, and the time of the event's opening and closing.
- Whether the event is benched or unbenched. If benched, hours dogs must be on bench must be included.
- List of the officers of the event-giving club, and the club secretary's address.
- List of the members of the Event Committee, and the Show Chair's address.
- Name and address of the AKC-approved superintendent or show secretary, and the name and address of the superintendent or show secretary who is to receive entries.
- Name and telephone number of the veterinarian or veterinary association, and whether the veterinarian will be in attendance or on-call at an unbenched show.
- Notice that the club may cancel the event due to extreme weather conditions.
- Name, address, and assignment of each judge. Asterisk next to the assignment of any judge that is permit at the time of the panel approval.
- When the event is an independent specialty and judging assignments will be drawn at the event, a statement to this effect.
- Notification if points for Reserve Winners at the National Specialty are **not** offered.
- Name of judge for tie-score run-offs, when an obedience class is split, or for high in trial.
- Statement that the event-giving club will collect recording and event service fees for the AKC.
- Closing date and time for entries. When the entries are limited at the event, include the number of entries, the reason for the limitation, and a statement that entries will close on the earlier of the specified closing date or when the limit is reached.
- Entry fee(s).

---

<sup>3</sup> Rules Applying to Dog Shows, Chapter 1, Sections 3, 4; Chapter 3, Section 23; Chapter 5, Sections 4, 6; Chapter 6, Sections 1-3, 5-9; Chapter 11, Section 2; Chapter 13, Section 1; Chapter 16, Section 1; Obedience Regulations, Chapter 1, Sections 2, 4, 5, 14, 16a, 27, 29; Chapter 10, Section 5; American Kennel Club Policy Manual, Section 4, Paragraphs IV-V; AKC Policy Memos, April 27, 1979, June 20, 1981, July 28, 1995; AKC Board Policy, February 2013, October 2013

- Statement that entries for exhibition only will not be accepted, when applicable.
- Description of restrictions, when the entries are restricted.
- Schedule of classification of breeds/varieties divided into groups, when the event is not a specialty.
- Exact classification of Miscellaneous breed classes.
- Eligibility and performance requirements for non-regular obedience classes not specifically defined in the Obedience Regulations, when they are offered.
- Notice that certain breeds may be judged on a ramp, with a list of those breeds.
- Restriction on the presence of unentered dogs, if any.
- List of prizes and trophies, with an accurate description of prizes, or the amount of monetary prizes. When a condensed premium list is used, include a notice that a list of prizes and trophies can be obtained from the superintendent or show secretary.
- Hours and location where private exercise pens may be set up.
- The following statement required by AKC<sup>4</sup>: "Exhibitors should follow their veterinarians' recommendation to assure their dogs are free of internal and external parasites, any communicable diseases, and have appropriate vaccinations." (Additionally, clubs should include any specific local or state health requirements; for example, proof of rabies vaccination).
- **Notice of video/televising, if the event will be filmed.**<sup>5</sup>
- Any additional rules, regulations or restrictions made by the club.
- If both indoors and outdoors, specify which breeds or classes will be judged outdoors.

## Recommended Information for Premium List

Additional information will help exhibitors make decisions about their show entries:

- Name of the club.
- Statement of the policy on refunding entry fees.
- Whether the event will be held indoors or outdoors.
- Details of special attractions approved by the AKC.
- The specified time when exhibitors and handlers can enter the site.

---

<sup>4</sup> AKC Board Policy, January 2004

<sup>5</sup> [AKC Board Policy, July 1998](#)

- Statement that judging procedure may be modified to accommodate disabled handlers.<sup>6</sup>
- List of suggested motels and directions to them.
- Overnight and reserve parking information, if available.
- Description of social activities for the exhibitors.
- Acceptable crates.
- Admission and parking fees, if any.
- Availability of amenities, e.g. electricity.
- Site map.
- Reserve grooming area, if available.
- Generator restrictions.

---

## Judging Program

The judging program lists the name of the club, date of the event, time scheduled for each breed, variety and obedience class and the starting time for groups.

Every club holding an event must prepare a judging program after the entries have closed. Two copies of the program **must** be mailed to the AKC's Event Operations Department at the time it is mailed to exhibitors. A copy of the judging program and an identification slip for each dog entered **must** be mailed to the owner of that dog **no later than one week before the date of the event**. Clubs may utilize electronic correspondence for judging programs at the exhibitor's request.<sup>7</sup>

A supply of judging programs and complimentary parking and admission ticket should be mailed to the Show Chair and Chief Steward in advance. The Show Chair can provide the judging program to committee chairs to help schedule workers (parking, trophy, concessions, etc.) throughout the day. The Chief Steward can use the judging program to help schedule enough stewards and to assure that those stewards will receive ample notice of being scheduled.

### Required Information for Judging Program<sup>8</sup>

- Number of dogs entered.
- Total number of dogs assigned to each judge.

---

<sup>6</sup> [AKC Board Policy, March 1998](#)

<sup>7</sup> [Rules Applying to Dog Shows](#), Chapter 7, Section 12

<sup>8</sup> [Rules Applying to Dog Shows](#), Chapter 7, Section 12; [Obedience Regulations](#), Chapter 1, Sections 26, 29; AKC Policy Memos, January 17, 1994, January 10, 2000

- Time scheduled for judging each breed or variety and obedience class.
- Time that group judging is scheduled to start and the order of group judging. The time and order of group judging may be changed from the original scheduled if a minimum of 30 minutes notice is given to exhibitors. In most instances any change in group judging will entail a later start time due to delays in breed judging that occurred earlier in the day. Group judging may only be moved earlier than the originally scheduled time when extenuating circumstances threaten the safety of dogs and people, e.g. impending severe weather or the required early evacuation of the show site. The decision to deviate from the original schedule is the responsibility of the Event Committee, in consultation with the Show Secretary/Superintendent and the AKC Executive Field Representative, if present. All breed judging for the group must be completed before judging of that group begins.

**EXAMPLE**

**RING ONE**

**12:45 PM Variety Groups Best in Show**

(The groups will be judged in the following order unless otherwise announced)

<b>Terrier</b> .....	<b>Judges Name</b>
<b>Hound</b> .....	<b>Judges Name</b>
<b>Working</b> .....	<b>Judges Name</b>
<b>Sporting</b> .....	<b>Judges Name</b>
<b>Non-Sporting</b> .....	<b>Judges Name</b>
<b>Herding</b> .....	<b>Judges Name</b>
<b>Toy</b> .....	<b>Judges Name</b>
<b>Best in Show</b> .....	<b>Judges Name</b>

- Any judge changes due to overloads, illness, etc.
- Entries assigned to each judge and division when an obedience class is split.
- Name, telephone number, and address for the veterinarian on call or on site, and for the 24-hour Animal Emergency Clinic if available, or the most convenient veterinarian's office.

## Recommended Information for Judging Program

Non-required information may be included in the judging program as a courtesy to the judges and exhibitors.

### Event Information

- Name of the club
- Emergency telephone number available during the event hours
- Whether the event will be held indoors or outdoors
- Hours the site is accessible
- Limits on exhibiting by club members or other parties
- Details about special attractions approved by the AKC
- Suggested motels, with details and directions
- Details about social activities for exhibitors

### Ring Assignments

Ring assignment(s) for each judge should include:

- Ring number.
- Time scheduled for judging.
- Number of regular class entries by sex.
- Number of Best of Breed/Variety entries by sex.
- Number of Non-regular breed entries by sex.
- Total number of dogs for each judges' assignment.
- Lunch break, if appropriate.

### Directions

Not all exhibitors make their entries from the premium list, so this information is important. Accurate written directions, including mileage and alternate routes should be clearly stated. This can be supplemented by a simple map that identifies roads to the event. Advise exhibitors of roadwork, unusual traffic conditions, etc.

Routes should be checked by the event-giving club for accuracy.

Directions that are helpful:

- To the airport.
- To an event immediately following the club's event.
- To suggested hotels.
- To emergency service locations.
- To the veterinarian's office (which may be the on-site veterinarian) or emergency clinic. Include a simple map to the office or clinic.

## Event Site Layout

Because not all exhibitors enter from the premium list, include a simple site layout, especially if the site is large or spread out. This can help to direct exhibitors to their correct grooming areas, rings, food, water, restrooms, etc. The AKC strongly recommends that clubs include the approved event site diagram in the judging program.

Clubs should contact their superintendent or show secretary regarding the inclusion of the event site layout in the judging program. See the example Site Layouts, pp. 13-49 – 13-53.

Notify the exhibitors and handlers of the specified time when they can enter the site. Allow at least two hours between the time when exhibitors can enter the event site and the time that judging starts. This allows time for exhibitors to arrive, unload, set up and prepare their dogs for the ring.

## Overnight Parking Information

Include cost, permitted arrival time, parking restrictions, alternate locations, etc.

## Material Mailed with the Judging Program

Additional items that a club may mail with the judging program include:

- Admission tickets.
- Windshield stickers for special parking or unloading areas limited to exhibitors.
- Notices of pre-show or post-show activities sponsored by the club.
- Notices of special attractions approved by the AKC.

---

## Catalog

Each event-giving club is responsible for the preparation of a catalog.<sup>9</sup>

The catalog may not go on sale until one hour prior to regular judging. Only those directly involved in its preparation may have prior access to the catalog information. Information on individual dogs entered may not be disclosed prior to the sale of catalogs.<sup>10</sup>

Catalogs for a multi-day event or cluster may be made available for sale one hour prior to judging of the first event included in the catalog.

---

<sup>9</sup> Rules Applying to Dog Shows, Chapter 12, Section 1

<sup>10</sup> American Kennel Club Policy Manual, Section 4, Paragraph VII.C

A club may pre-sell catalogs through an ad in the premium list. This would assure the club of selling a minimum number of catalogs, and allow a better estimate of the number of catalogs needed at the event.

For pre-event sales, the entry form must include a box to be checked on the top portion of the form, and a notice that payment for the catalog should be included with the entry form.

Clubs holding back-to-back events or different clubs in a cluster may use a combined catalog provided it meets all requirements. A separate marked copy for each event must be sent to the AKC with all of the dogs not entered in that specific event crossed out.<sup>11</sup>

The optional inclusion of OFA and CERF numbers is permitted. Sample wording on the premium list is:

#### OFA AND CERF INFORMATION ACCEPTABLE ON ENTRY FORM

Only official AKC titles may be included in the catalog. See the list of Official AKC Titles for Catalog, pp. 13-34 – 13-36. A complete and current listing of all prefix, suffix, and parent club title along with all title recognition programs can be found at [www.akc.org](http://www.akc.org) by searching for AKC Titles and Abbreviations.

A list of Class Divisions is included on pp. 13-37 – 13-41.

To distinguish those handlers accepted into the AKC Registered Handlers Program, the following affiliation with the AKC Registered Handlers Program must be included **bold** in the catalog.<sup>12</sup>

Example:

**CH TAKEITZ PETTYBOY NM112233/11.** 5/14/1999. Dog Breeder: Jane Smith  
By Ch I'm in the Money - Ch Lady Marmalade. Owner: John Doe & Mary Smith,  
123 Lovers Lane, Palm, FL, 34990-5669. (**JANE DOE, AKC Registered Handler,  
DHG**)

## Required Information for Catalog<sup>13</sup>

On the cover or title page:

- Date or dates of the event
- Name of the show-giving club(s)
- Notice that the event is held under American Kennel Club rules
- American Kennel Club logo

---

<sup>11</sup> [AKC Board Policy, July 2013](#)

<sup>12</sup> AKC Board Policy, August 2001

<sup>13</sup> [Rules Applying to Dog Shows](#), Chapter 7, Section 12; Chapter 12, Sections 1-7; [Obedience Regulations](#), Chapter 1, Section 26, AKC Board Policy, August 2001



- The words “Licensed Show” when the event-giving club is not a member of the AKC
- Event's exact location and time of opening and closing
- List of officers of the event-giving club
- List of the members of the Event Committee, and the Show Chair’s address
- Name, complete address, and assignment of each judge
- Name and address of the Superintendent and/or Show Secretary
- Name of the veterinarian or veterinary clinic, and whether the veterinarian will be in attendance or on-call
- Names and addresses of all exhibitors
- Information on all entered dogs: catalog number; complete name; registration, PAL or AKC-issued identification number; foreign registration number and country if foreign-registered; date of birth; breeder(s); sire and dam; owner(s)/co-owner(s); owner's address; agent, if any, and agent's affiliation with the AKC Registered Handlers Program (in bold)
- Information on all entered Junior Handlers
- Copy of the judging program
- List of prizes and trophies
- Schedule of points
- American Kennel Club approved breed standard when the event is an independent national specialty show

## **Recommended Information for Catalog**

- The AKC Secretary's certification that permission has been granted for the club to hold the event
- Show Chair's telephone contact information
- Veterinary clinic's telephone number
- Space for recording award information for each breed



## 10: Required Items for Event Operations

<b>Deadlines</b> _____	<b>10-2</b>
Before the Event .....	10-2
Online Event Management .....	10-3
After the Event .....	10-3
<b>Event Operations Approval</b> _____	<b>10-3</b>
Corresponding Dates .....	10-3
Closing Dates .....	10-4
Number of Events .....	10-4
Duration of Events .....	10-4
Club Territory .....	10-4
Relinquishing Breed Classes.....	10-5
Event Conflict Distant .....	10-5
Back-to-Back or Multiple Events.....	10-6
Local Specialty Clubs .....	10-6
Clusters and Back-to-Back Shows .....	10-7
<b>Site Layouts</b> _____	<b>10-8</b>
<b>Event Records</b> _____	<b>10-9</b>
<b>Materials Required at the Event</b> _____	<b>10-9</b>
Judges Books .....	10-9
Ribbons and Badges .....	10-9
Forms and Other Paper Items .....	10-9
Scales .....	10-10
Procedure for Weighing.....	10-10
Wickets .....	10-10
Ramps .....	10-10
Mats .....	10-11
Tenting.....	10-11
Ring Enclosures.....	10-11
AKC Banners and Signs .....	10-11
Publications .....	10-12
Filming at Events .....	10-12

---

## Deadlines

All paperwork should be submitted at the earliest possible date so that the event will receive maximum advertising exposure on the AKC's website, and so that problems can be resolved well before the event.

Mail, email or fax the items to the AKC's Event Operations Department.

### Before the Event

<b>18 weeks prior to the event's closing date</b>	Submit the <a href="#">Application for Show/Trial</a> . <sup>1,2</sup> Fines may be levied for late submittal.
	Complete the <a href="#">Disaster and Emergency Plan</a> . <sup>2,3</sup>
	<a href="#">Statement of Compliance</a> <sup>2</sup> (does not have to be submitted to AKC but activities must be completed annually for all-breed, group and specialty clubs).
	Submit a current <b>Officers/Membership List</b> (annually for all clubs).
	Submit the <a href="#">All-Breed</a> or <a href="#">Specialty Judges Panel</a> . <sup>2,4</sup> Fines may be levied for late submittal.  Event Operations has created a <a href="#">Checklist</a> of items that should be submitted with an event application to assist clubs.
<b>5 weeks prior to the closing date</b>	Send the <b>Premium List</b> to exhibitors, with copies to the AKC. <sup>5</sup>
<b>1 week prior to the show date</b>	Send the <b>Judging Program</b> to exhibitors, and copies to the AKC. <sup>6</sup>

The [Special Attractions Application](#)<sup>7</sup>, if any, must accompany the Application for Show/Trial.

If the event will be filmed, the Club Secretary must send a letter notifying the Event Operations department that the club intends to participate in a media event.<sup>8</sup>

---

<sup>1</sup> [Rules Applying to Dog Shows](#), Chapter 2, Sections 4, 9

<sup>2</sup> Form may be downloaded from the AKC web site

<sup>3</sup> AKC Board Policy, March 1998

<sup>4</sup> [Rules Applying to Dog Shows](#), Chapter 4, Section 1

<sup>5</sup> [Rules Applying to Dog Shows](#), Chapter 4, Section 2

<sup>6</sup> [Rules Applying to Dog Shows](#), Chapter 7, Section 12

<sup>7</sup> Form may be downloaded from the AKC web site

<sup>8</sup> AKC Board Policy, July 1998

## Online Event Management

This system allows clubs to enter Event Applications, Judges Panels and Disaster and Emergency Plans on-line, including last minute edits, if necessary.

The AKC will assign each club a unique account ID and password to access the Online Management System. To obtain an ID and password, a club officer must contact the AKC by e-mail at [eventplans@akc.org](mailto:eventplans@akc.org). The e-mail addresses are:

- Conformation, Obedience/Rally and Tracking.....[eventplans@akc.org](mailto:eventplans@akc.org)
- Agility.....[agilityonlineapp@akc.org](mailto:agilityonlineapp@akc.org)
- Field Trials, Hunting Tests, Herding,  
Lure Coursing, Earthdog.....[performanceevents@akc.org](mailto:performanceevents@akc.org)

Each club will be given only one account ID and password; the information will be given only to a club officer. The ID and password can then be shared with the various event chairpersons, allowing them to manage their specific event online. See Chapter 5 of this manual for further details.

### After the Event<sup>9</sup>

The Show Records, the [Report of Dog Show or Obedience or Rally Trial form](#), and the Recording Fee **must reach the AKC's Event Operations Department within 7 calendar days of the Show/Trial.**

---

## Event Operations Approval

Clubs should be aware of the policies and procedures concerning the approval of show and obedience trial dates and judging panels. Direct all inquiries to the Event Operations Department.

### Corresponding Dates

The AKC uses a system of corresponding dates based on show weekends of the year. The AKC considers the first show weekend of the year the first week in which neither January 1st nor 2nd falls on a Saturday. Once the first show weekend for the year has been established, all other show weekends follow in order.

Once a club holds an event, the club owns an established corresponding date, which is protected for subsequent years unless the club fails to hold an event in a given year or changes its event date.<sup>10</sup> Within the club's specified territory,

---

<sup>9</sup> Rules Applying to Dog Shows, Chapter 17, Section 2

<sup>10</sup> Rules Applying to Dog Shows, Chapter 2, Sections 2, 5

no other club would be approved for an event offering the same competition types on that corresponding date, without that club's express permission. If a club fails to hold an event within its territory for two consecutive years, it loses its exclusive rights to that territory.<sup>11</sup>

The [Corresponding Date Table](#) is published on the AKC website and is included in this manual on p. 13-32 – 13-33.

## Closing Dates

All events must have an entry closing date. For all shows other than specialty shows, the specified closing date and time must be determined as outlined in the [Rules Applying to Dog Shows](#).<sup>12</sup>

## Number of Events

Conformation clubs may hold two events per year, except all-breed clubs in geographically isolated areas, which may hold up to four shows per year. A geographically isolated area is defined as those parts of the United States where there are no other all-breed clubs within 75 miles, and all of Alaska, Hawaii, and Puerto Rico.

National breed clubs have no limit to the number of events they may hold in a year.

Any number of independent obedience trials may be held by any club that the AKC has approved to hold them.<sup>13</sup>

## Duration of Events

All-breed clubs are normally limited to one-day events. For an event to exceed two days, the club must obtain the AKC's permission.<sup>14</sup> Once an all-breed club planning a two-day show gives up one of the days for that show, it cannot revert to two days for that show.

## Club Territory

The AKC's Club Relations Department establishes club territories and geographic areas.

A club should try to hold its events within its geographic area. Before a club makes any commitment for a site not previously used, the AKC's Event Operations Department must be contacted to verify that the site can be approved.

---

<sup>11</sup> [Rules Applying to Dog Shows](#), Chapter 2, Section 5

<sup>12</sup> [Rules Applying to Dog Shows](#), Chapter 6, Section 9

<sup>13</sup> [Obedience Regulations](#), Chapter 1, Section 2; [American Kennel Club Policy Manual](#), Section 4, Paragraph I.B

<sup>14</sup> [Rules Applying to Dog Shows](#), Chapter 2, Section 20

A club seeking the AKC's permission to hold an event within the territory of another club that holds the same type of event must obtain written permission from that club and include it with the event application.<sup>15</sup>

### **Relinquishing Breed Classes (Mileage Conflict Clause)**

The AKC will only approve a non-member specialty club that wants to hold an event on the same day, during the same hours as an all breed event, if certain conditions are met. If the non-member specialty is within 200 miles of an all-breed event, the non-member specialty can only be approved if the all-breed club relinquishes its event's classes for that breed. However, if the non-member event is within 100 miles the all-breed event, the non-member event can only be approved if the all-breed club also excludes obedience, rally and agility trial classes for that breed.

When a national breed club wants to hold a National Specialty event within a 200-mile radius of an all-breed club, on the all-breed club's corresponding date, the all-breed club may choose to give clearance to the national breed club and:<sup>16</sup>

- Relinquish its event's classes in the breed, obedience, rally and agility classes.
- Co-exist, i.e. both clubs offer classes.

The maximum number of breeds that may be relinquished/excluded, by an all-breed club is five, for any type competition. Breeds with varieties are counted as one breed.

Conformation dog shows may not be held closer than 200 miles in distance on the same day, except a club may be approved to hold a show within 200 miles of another club which has established its show on the same date, only if in each instance it obtains the written permission of the club with the established date and submits the written permission along with its show application. The American Kennel Club will only enforce any agreements between the clubs if they are in writing and signed by officers of the respective clubs. It is the club's responsibility to insure the length of their commitment to the show location is consistent with the written permission they receive from the established club.<sup>17</sup>

### **Event Conflict Distances**

<b>Type Event</b>	<b>Protected Distance</b>
Conformation	200 Miles
Agility	100 Miles
Obedience	100 Miles
Rally	100 Miles

---

<sup>15</sup> [American Kennel Club Policy Manual](#), Section 4, Paragraph I.C

<sup>16</sup> [American Kennel Club Policy Manual](#), Section 4, Paragraph I.D

<sup>17</sup> [AKC Board Policy, February 2014](#)

## **Back-to-Back or Multiple Events<sup>18</sup>**

All-Breed, Group, national breed specialty, and breed specialty clubs may hold their events for the year in any sequence of dates.

The events must be held within a 125-mile radius of the club's territory, and are subject to the host club's approval if applicable.

For all-breed, group, and specialty clubs, if both events are held out of their territory, double compliance with [AKC educational requirements](#)<sup>19</sup> will be necessary for AKC approval.

## **Local Specialty Clubs:<sup>20</sup>**

Local breed specialty clubs will be approved to hold back-to-back shows that meet the normal conflict criteria for approval.

The following additional information is the mileage criteria presently used when approving local breed specialty events. For local breed specialties outside of a club's licensed area:

- Local specialty clubs are limited to 125 straight line miles from their territory as per current policy.
- Specialty clubs joining another specialty club of the same breed are limited to 200 miles from their territory.
- Specialty clubs joining the designated National Specialty are limited to 500 miles from their territory.

Parent Clubs are encouraged to review distances involved and impact on other specialty clubs prior to approval of their member club event request. Clubs may request a one-time exception from Event Operations through their Parent Clubs if distance limitations cause undue hardship on the club and no other specialty club, of the same breed, is bypassed without their concurrence.

Two independent specialty shows of the same breed of no more than one hundred entries each, inclusive of sweepstakes, special attractions or matches, may be permitted at the same location on the same day.<sup>21</sup>

Specialty clubs that wish to combine their obedience entries with those of other specialty clubs may organize clusters. See the *Obedience/Rally Trial Manual* for further details and requirements.

---

<sup>18</sup> AKC Board Policy, April 1999, May 2000

<sup>19</sup> Form may be downloaded from the AKC web site

<sup>20</sup> AKC Board Policy, February 2006

<sup>21</sup> AKC Board Policy, December 2005

## Clusters and Back to Back Dog Shows<sup>22</sup>

A cluster is defined as more than two events, each held by a different club, at one site on consecutive days. The cluster's host club (one that owns the territory or site, and date) must be clearly identified to the AKC, if there is a host club.

A cluster committee consisting of a representative from each club must be established to coordinate dates, grounds, special attractions, etc. The Cluster Site Guidelines, p. 13-42, and the Site Inspection Checklist, pp. 13-28 - 13-30, provide some guidelines for the cluster committee.

Clusters will consist of four or fewer events. In no circumstances will clusters of more than five days of unique AKC conformation events be approved. Approval of more than four days of unique AKC conformation events is contingent upon:

- The site is exceptionally suitable,
- An AKC Executive Field Representative gives a positive recommendation, and
- The Event Operations Department approves the site.

Continuation of cluster approval for subsequent years will be based on:

- Daily inspection by the AKC Executive Field Representative, the club and the superintendent. See the Cluster Site Inspection Guidelines, pp. 13-43 - 13-46.
- Monitoring of conditions during the cluster to verify that they provide dogs and exhibitors with stable and safe venues.

Effective July 1, 1999: A cluster committee consisting of a representative from each club must be established to coordinate dates, grounds, special attractions, etc. The function of the cluster committee is to coordinate overall plans for the cluster. Each club remains responsible for the management of its own event. The individual event committee must comply with existing AKC Rules, Regulations and Guidelines. Guidelines for the cluster committee follow:

- Each club remains responsible for the conduct of its own event.
- Each club will have one representative on the Cluster Committee.
- Work out event schedule at least one year in advance. Any date conflicts must be resolved by the clubs.
- Submit all event applications together in one package to event plans, if possible. This will prevent unnecessary delay in issuing all event approvals. This applies to applications for "regular" shows, not designated specialties.

---

<sup>22</sup> [AKC Board Policy, September 1996, May 2000, February 2005, June 2014](#)



- Judges selection, contracts, etc. are the responsibility of the individual show-giving clubs and any disputes must be worked out by the clubs.
- Common site application form may be submitted in lieu of individual host club letters. Form must be signed by all club representatives.
- Club Representatives will work with Executive Field Representative, Grounds Chair/Committee and Superintendent on daily site inspections for their respective events.
- Cluster committee may remain the same from year to year.

**Cluster committee would also be responsible for the following:**

- Securing accessory services and equipment such as telephones, public address system, potable water, chairs and tables, all concessions.
- Submitting a consolidated Emergency and Disaster Plan form to event plans. The form should identify all clubs in the cluster and their event dates. The form may be signed for the cluster committee by a designated individual.
- Dealing with outside personnel such as site management.
- Making sure there is adequate insurance coverage for all clubs/days.
- Each club is responsible to identify itself on its event application as part of a cluster.
- The Common Site Application must accompany the event application for all participating clubs.

---

## Site Layouts

Before approving a site, the Event Operations Department reviews the event layout to determine the suitability and optimum use of a site. The Event Operations Department may impose entry limits if the site layout shows that the site has limited space or on the recommendation of the AKC Executive Field Representative.

If the site is new or if the club is making changes from its previous event, a layout must be submitted with the event application.

If an all-breed club is using a site not previously approved, an AKC Executive Field Representative must make an on-site examination and file a written report before the AKC will grant approval.

There are examples of site layout diagrams beginning on p. 13-49.

If offering reserved grooming space a site layout must be submitted with your event application.<sup>23</sup>

---

## Event Records

The Event Operations Department processes and posts all event results and AKC titles for conformation, and obedience. Clubs must submit the following in time to reach the Event Operations Department within seven days after the conclusion of the event:<sup>24</sup>

- A marked catalog,
- The judges books,
- A Secretary/Superintendent's Report,
- The recording and event service fee .

Any questions concerning previously submitted records should be directed to the Event Operations Department or to Special Services.

---

## Materials Required at the Event

Materials that a club must have at the event can be obtained from various sources.

### Judges Books

The AKC does not supply judges' books. They may be purchased from superintendents. See the list of Licensed Superintendents on pp. 13-6 - 13-7.

Clubs that print their own books must follow the AKC formats on pp. 13-70 - 13-71. Books may be typed or printed, and may be prepared on any type of presentable paper stock. Pages must be in quadruplicate.

### Ribbons and Badges

All ribbons and rosettes must conform to the AKC's requirements.<sup>25</sup>

Ribbons and badges may be purchased from most local ribbon companies or from superintendents.

### Forms and Other Paper Items

Arm bands, obedience score pads, blank entry forms, directional arrows and posters may be obtained from many of the large dog food companies or purchased from superintendents. Examples of Obedience/Rally Score Sheets can be found in the Obedience/Rally Trial Manual.

---

<sup>23</sup> [AKC Board Policy, July 2012](#)

<sup>24</sup> [Rules Applying to Dog Shows](#), Chapter 17, Section 2

<sup>25</sup> [Rules Applying to Dog Shows](#), Chapter 5, Sections 1-3

## Scales

The Event Committee, or their superintendents if the event committee gives them this responsibility, is responsible for providing accurate, functioning scales at every show.<sup>26</sup>

A balanced scale that shows weight in pounds and ounces or fractions of pounds must be available. An electronic digital scale is also acceptable; a bathroom scale is not. A test weight must also be available at the event.

### Procedure for Weighing

1. Bring scale to ring with test weight(s).
2. Place scale on a flat surface.
3. Adjust scale to zero.
4. Place test weight(s) on scale, check reading and remove weight(s).
5. Weigh the dog.

A four-or-five-pound test weight is available from most scale companies. A five-pound bag of sugar is not an acceptable test weight.

## Wickets<sup>27</sup>

*Event committees for the larger all-breed shows, or their superintendents if the event committee gives them this responsibility, are required to have two large (17"-30") wickets, and two small (8"-17"), available at every all-breed show. Clubs in the continental United States that have fewer than 1,000 entries at their events, and clubs located in Alaska, Hawaii and Puerto Rico, are required to have one complete set of wickets (1 large, 1 small) available.<sup>28</sup>*

*Event committees for specialty shows, or their superintendents if the event committee delegates this responsibility to them, are responsible for having one wicket, or the one set of wickets applicable to that breed, available at every show.*

*Large Adjustable Wickets (17 - 30 inches) and Small Adjustable Wickets (8 - 17 inches) may be purchased from the AKC. To purchase wickets, you may contact the Customer Service Department.*

## Ramps<sup>29</sup>

At the discretion of the judge, certain breeds may be judged on a ramp. The Class Divisions section beginning on p. 13-37 contains a list of those breeds. A complete current list of all ramp breeds can be found at [http://images.akc.org/pdf/judges/table\\_breeds.pdf](http://images.akc.org/pdf/judges/table_breeds.pdf). A judge requesting the

---

<sup>26</sup> Rules Applying to Dog Shows, Chapter 14, Section 5; American Kennel Club Policy Manual, Section 4, Paragraph VI

<sup>27</sup> American Kennel Club Policy Manual, Section 4, Paragraph VI

<sup>28</sup> Rules Applying to Dog Shows, Chapter 14, Section 5

<sup>29</sup> AKC Policy Memo, July 26, 1999

use of ramp must give reasonable notice to the show superintendent/show secretary prior to judging.

The premium list contains a notice advising prospective entrants that a ramp may be used in judging. **Ramps may be used in emergency situations to judge any breed, but if the use of a ramp is not indicated in the premium list, exhibitors may withdraw their entries and receive a refund.**

AKC approval is not required for a judge to use a ramp.

See Judging Ramp Specifications, p. 13-47, for general guidelines for ramp construction.

## **Mats**

A club that needs mats for its rings should contact other clubs in its area to determine where mats can be rented or obtained. Clubs may contact the superintendent to see if they provide mats.

## **Tenting**

Clubs **must** provide some type of adequate shade at sites that do not have a reasonable amount of protection from the heat.<sup>30</sup> Remember to check with site management for permission and placement of tents. Local townships may require permits for tenting.

Club may secure tenting through the show superintendent or from a rental company. See the list of Tenting Companies, p. 13-12.

## **Ring Enclosures**

Material to clearly define rings must be provided. A variety of items may be used, such as baby gates, stanchions, ropes, etc.

Be sure that there is ample space between the mats and the ring enclosures for people gaiting their dogs.

## **AKC Banners and Signs**

The AKC provides superintendents with banners and signs to be displayed at shows.

---

<sup>30</sup> American Kennel Club Policy Manual, Section 4, Paragraph I.L; AKC Policy Memo, January 31, 1994



All clubs using an AKC licensed superintendent and those superintendents must display banners and signs provided by AKC to those superintendents at their shows. The banners and signs containing the AKC logo must be placed in prominent and highly visible areas. The banners must be hung on visible walls under tents at outdoor shows and directly on show rings. The signs must also be in highly visible areas, such as near a busy show entrance, near catalog sales points, one near the Best in Show ring during judging and as part of the backdrop for the show photographer. The superintendent and show-giving clubs are responsible for coordinating the placing of the banners and signs.

Clubs that are not using the services of a Superintendent are strongly encouraged to display AKC banners and signs at their event. These banners and signs may be purchased from AKC.<sup>31</sup>

## Publications

Copies of the following publications are required to be on site at the event:<sup>32</sup>

- The latest edition of The Complete Dog Book, or a current set of the applicable breed standards.
- Rules Applying to Dog Shows
- Rules Applying to Registration and Discipline
- Dealing with Misconduct
- Conformation Junior Showmanship Regulations, Guidelines for Judging Juniors in Conformation, Juniors in Performance Events
- Show/Trial Manual
- Obedience Regulations, Obedience Judges Guidelines, The Steward in Obedience, Rally Regulations, Rally Judges Guidelines, The Steward in Rally, if applicable.

Publications may be ordered from the Order Desk (919) 233-9767 or by visiting [www.akc.org/store/projects/index.cfm](http://www.akc.org/store/projects/index.cfm).

## Filming at Events<sup>33</sup>

Clubs planning media events must follow the procedures and policies below:

- Include a notice in the premium list that the event will be videotaped or televised.
- Notify judges that the event will be videotaped or televised.

### AKC POLICY ON CONTRACTUAL REQUIREMENTS FOR COMMERCIAL FILMING AND/OR ELECTRONIC TRANSMISSION OF ITS APPROVED EVENTS

<sup>31</sup> [AKC Board Policy, July 2002](#)

<sup>32</sup> [Rules Applying to Dog Shows](#), Chapter 2, Section 18

<sup>33</sup> [AKC Board Policy, July 1998](#)

The Board shall develop and publish specific and mandatory contractual requirements governing the conduct of all persons engaged in the commercial filming and/or electronic transmission of AKC-approved dog events. The clubs holding these AKC-approved events are responsible for enforcing these requirements, and are prohibited from entering into any contract which would place them in violation of these requirements.

When a club makes application to AKC for permission to hold their event, they must include in that application a declaration that their event will or will not be commercially filmed or electronically transmitted.

Any AKC member or licensed club seeking approval to conduct a dog event involving commercial filming and/or electronic transmission of their show must include good faith participation of AKC and its representative professional sports marketing consultant in the negotiation of the contract terms, and AKC must appear as a third party signatory on the fully executed contract *before their application for the show will be approved*. Clubs will have the discretion to seek additional professional representation at their option and expense, if desired.

The Board of Directors will develop and publish the minimum requirements that any such contract must contain, which will be facilitated by the professional sports marketing consultant. Essential to such contracts will be:

1. Reasonable recognition, both visually and orally, of the event-giving club and the AKC.
2. Reasonable monetary compensation for the event-giving club and for AKC.
3. Assurance that commercial filming or electronic transmission of any AKC approved event will not diminish or impugn the reputation of the sport of purebred dogs, the event-giving club, or AKC.
4. Defined amounts of airtime devoted to the promotion of the sport of purebred dogs and AKC.
5. Exercise of a good faith effort to avoid scheduling conflicts with the airing of other AKC dog events.
6. Assurance for compliance with current AKC "Operational Requirements for Commercial Filming and Electronic Transmission at Events" policies and procedures, a copy of which shall be attached as an addendum to the contract.
7. Provision for confidentiality.

The effective date of the policy will coincide with the date of its approval by the Board of Directors, and the Board shall define disciplinary action for clubs which fail to comply. The Board shall also make special provision for clubs that have permitted electronic transmission of their past shows and that have contracts already in force on the date the Board implements this policy. Any waiver of this policy must be approved by AKC.

## **Operational Requirements for Commercial Filming or Electronic Transmission of Events**

This AKC operational policy is applicable to all filming or electric transmission of events and will be used in conjunction with the AKC Board Policy concerning Contractual Requirements for Commercial Filming or Electronic Transmission of Events.

### **Requirements for media crews and equipment at all events**

- No lights, cameras, equipment, or personnel that distract or in any way affect the performance, health or welfare of dogs, exhibitors and/or judges will be allowed.
- Published judging schedules may not be delayed to accommodate filming or production.
- Filming may not obstruct the grounds, aisles, or passageways, nor disturb exhibitors, dogs, or judges, or cause undue obstruction to spectators during any portion of the event.
- Filming or recording may not attract undue attention to specific exhibits or exhibitors that could afford unfair advantage for certain competitors. This restriction includes the use of individual microphones on exhibitors. Use of individual microphones on exhibitors must be clearly described by the media crew and approved by AKC.
- The AKC Executive Field Representative or a designated AKC liaison will be the final on-site authority to interpret AKC Policy should site-specific regulatory questions arise. The Event Chairman is responsible for complying with AKC Rules, Regulations and Policy at the event.
- Film crew and the event chairman will meet immediately prior to the event to identify and resolve any limitations or restrictions pertaining to the specific venue.

**Trials and Tests:** The event's chairman and judges have complete authority over the areas used for trials or tests. As such, they have responsibility to assure that filming will not interfere with the successful running of the event. In all cases, safety is to be a top priority and must not be compromised.

**Events with Rings:** No film crews or equipment will be allowed to block the ring entrance or aisles leading to the ring.

- Any equipment or lights placed inside, above or around the ring must not interfere with normal judging procedures.
- Filming will typically be conducted from outside the ring. Limited filming may be permitted inside the Specialty Show, Group or Best in Show ring subject to AKC approval of the position of cameras, equipment, and personnel. Cameras or cameramen must remain in a stationary position when filming in the ring. Any activity that disturbs the exhibits, exhibitors or judges will not be permitted to continue under any circumstances. Cameras

filming the lineup of dogs should be done in an area outside the judging ring or from a stationary camera as the dogs enter the ring for judging. If a designated lineup area is not available or the stationary in-ring camera not suitable, a brief filming of the lineup in the ring prior to each Group and Best in Show judging may be requested. This filming of the lineup in the ring by cameramen must not exceed three minutes prior to any Group or Best in Show.

- All cameras (including boom cameras) must maintain a designated distance from the dogs at all times. This distance will be discussed and approved by AKC prior to the start of filming.
- AKC approved cameramen will be considered “show attendants” for the application of Chapter 7, Section 16 of *Rules Applying to Dog Shows*. “Judges are required to exclude from the rings in which they are judging all persons except the steward or stewards and the show attendants assigned to the ring and those actually engaged in exhibiting.”

*\*Note: Editorial news coverage filming need not be published or coordinated with Event Operations, but will require permission from the Event Chairman with applicable compliance with the directions and filming limitations required by this policy.*

The club is responsible for insuring that the filming does not interfere with the normal operation of the event. Personnel should be assigned to monitor conditions so that:

- No camera person blocks any ring entrance or aisles leading to rings,
- No lights or other distracting equipment affects the dogs, exhibitors or judges,
- Equipment placed inside, above or around a ring does not interfere with judging,
- Videotaping does not delay the published judging schedule,

Judges are required to exclude anyone but exhibitors, stewards and show attendants from their rings.<sup>34</sup>

### **Policy Covering Exclusions from AKC Contractual Requirements Policy for Personal or Limited-Use Viewing<sup>35</sup>**

Clubs contemplating “limited-use” filming-only at AKC -approved events will be granted automatic exception from compliance with AKC Policy on *Contractual*

---

<sup>34</sup> Rules Applying to Dog Shows, Chapter 7, Section 16, Rules, Policies, and Guidelines for Conformation Dog Show Judges, pg. 25.

<sup>35</sup> AKC Policy, July 2005



*Requirements for Commercial Filming and/or Electronic Transmission of Approved Events.* "Limited-use" filming is defined as:

The recording of moving images by individuals or professional videographers solely for personal consumption or for the purpose of producing a record of the winners for members and the fancy who have special interest in the event, and which is not intended for mass commercial transmission or distribution.

Exclusion from the Contractual Requirements Policy under these circumstance, however, does not preclude the need for Clubs to comply with the *Policy for Operational Requirements for Commercial Filming or Electronic Transmission of AKC Approved Events* pertaining to the use of cameras, lighting or personnel needed to film the event's activities, as ultimately monitored and overseen by the show chairperson.



---

# 11: Show Superintendents and Secretaries

<b>Event Entries</b> .....	<b>11-2</b>
Receiving Entries .....	11-3
Fax Entries .....	11-3
Telephone Entry Services .....	11-3
Online Entries .....	11-3
Changing and Correcting Entries .....	11-4
Cancellation of Entries .....	11-5
Change of Judge .....	11-5
<b>Records</b> .....	<b>11-5</b>
Electronic Transmission of Show Results .....	11-6
<b>Superintendents' Contracts</b> .....	<b>11-6</b>
Services Furnished by the Superintendent .....	11-7
Expertise .....	11-7
Printing .....	11-7
Mailing .....	11-7
Equipment .....	11-7
Services Furnished by the Club .....	11-8
Premium List Information .....	11-8
Proofreading .....	11-8
Event Site .....	11-8
<b>Package Contracts - Superintending Services</b> .....	<b>11-8</b>

Every club seeking approval to hold an AKC licensed or member dog show, obedience, agility or rally trial, tracking or performance event is required to designate a superintendent or a show secretary to perform the duties described in the Rules Applying to Dog Shows.<sup>1</sup> The services of an AKC-licensed superintendent may be used to reduce the number of independent contractors needed to produce an event. The convenience of dealing with one contract and dependence of the club on the superintendent's expertise must be weighed against the expense for their services.

When a club engages a superintendent for services, both are entering a contract, legally binding to both parties. The AKC does not assume any responsibility for either a superintendent's or a show secretary's performance of obligations to the event-giving club. The club is held responsible to the AKC if the superintendent or show secretary fails to comply with AKC rules and regulations.

Any qualified person may be approved by the AKC to act as a show or trial secretary.<sup>2</sup> The person must be in good standing with the AKC, be knowledgeable about all aspects of the show secretary job, and be well-versed in the latest AKC rules, regulations and policies pertaining to dog shows, obedience, agility, or trials, tracking or performance events.

A list of Annually-Licensed Superintendents is located on pp. 13-6 – 13-7 of the manual. A current listing can also be found on the [AKC website](#).

---

## Event Entries

The superintendent's or show secretary's responsibilities include receiving entries before the event.

For an event entry to be acceptable, the superintendent or show secretary must receive a complete, signed entry form prior to the closing date and time, at the address specified in the premium list.<sup>3</sup> [Blank entry forms](#)<sup>4</sup> can be obtained from the AKC.

A properly completed entry will have the following information filled in: name and date of the event; the required fee; the breed; the variety (if any); the sex; the class; the full name of the dog; and the AKC registration number, individual foreign registration number, PAL Number (for Obedience, Rally, Agility, Performance and Junior Showmanship only), or identification number issued by AKC.<sup>5</sup>

---

<sup>1</sup> Rules Applying to Dog Shows, Chapter 8

<sup>2</sup> Rules Applying to Dog Shows, Chapter 9, Section 2

<sup>3</sup> Rules Applying to Dog Shows, Chapter 11, Section 4

<sup>4</sup> Form may be downloaded from the AKC web site

<sup>5</sup> Rules Applying to Dog Shows, Chapter 11, Section 4

Conditional entries will not be accepted.<sup>6</sup>

To keep track of entries as they are received and to have a ready reference, the superintendent or show secretary may find it helpful to prepare check sheets. Anyone selected to help process entries should be familiar with the procedure.

All entry forms should be on hand at the event, arranged in catalog order, and separated by group and breed. The superintendent or show secretary can easily refer to these forms to answer any questions exhibitors may raise.

## Receiving Entries

The AKC allows entries to be submitted by mail, by fax, by telephone, and by online entry.

### Fax Entries

Fax entries must be made on an official AKC entry form and include **both sides** of the entry form. A separate entry must be faxed for each dog for each show entered. Payment by credit card must accompany all entries.

### Telephone Entry Services

Subscribers to such a service must complete a master entry form for each dog they intend to show; the master entry would be kept on file by the service. The service must generate an entry form for each dog entered under this system. The entry must be identifiable as a telephone entry. Payment by credit card must accompany all entries.

### Online Entries

Online entries are subject to the same requirements as mail, fax and telephone entries. Additional requirements or conditions may be imposed by the online service. All online entry instructions should be clearly written. Payment by credit card must accompany all entries.

---

<sup>6</sup> Rules Applying to Dog Shows, Chapter 11, Sections 5, 14

## Changing and Correcting Entries

The Rules Applying to Dog Shows stipulates that entries may not be canceled or changed after the closing date. The only exceptions are:<sup>7</sup>

- The Superintendent or Show Secretary may make corrections to either the dog's name or number, never both, provided all other information on the entry form is correct.
- The Superintendent or Show Secretary that validates entries with AKC records may correct the dog information to match the AKC registration data for the dog as specifically authorized by the AKC.
- A dog may be transferred, one half-hour prior to any regular judging at the show, from one division of the Puppy Class to another or between the Puppy and Twelve-to-Eighteen-Month classes.
- Dogs that have completed the requirements for a championship after the closing of entries for the show may be transferred or “moved up” from one of the regular classes to the Best of Breed or Variety Competition. This transfer must be made at least one half-hour prior to the start of any **regular** conformation judging at the event. In a multiple-day event, any transfer must be made at least one half-hour prior to the start of any regular conformation judging at the show on the day in which the entrant's class is to be judged.
- A dog determined to be ineligible, by its owner/agent, for the class in which it has been entered may be transferred to an eligible Open Class at a show prior to the judging of any regular conformation class within the sex of that breed or variety.
- Junior handlers who win a third Novice class, with competition, after the closing of entries may transfer their entries from the Novice class to the Open class. Junior handlers that meet the criteria to enter the Master class, after the closing of entries may transfer their entries from the Open class to the Master class. This transfer must be made at least one-half hour before the scheduled start of Junior Showmanship judging at the show.<sup>8</sup>
- Junior handlers may make a substitute of dogs. This must be done with the Superintendent or Show Secretary at least one-half hour before the scheduled start of Junior Showmanship judging at the show.<sup>9</sup>

---

<sup>7</sup> Rules Applying to Dog Shows, Chapter 11, Section 6

<sup>8</sup> Junior Showmanship Regulations, Section 5

<sup>9</sup> Junior Showmanship Regulations, Section 7

## Cancellation of Entries

No entry may be changed or canceled by telephone. All changes or cancellations, except those resulting from a judge change, must be made in writing, by fax, or by email and received by the superintendent or show secretary prior to the **closing date** and time.<sup>10</sup>

### Change of Judge<sup>11</sup>

If a new judge is substituted for the judge advertised in the premium list, affected exhibitors are entitled to withdraw their entry and receive a full refund.

If the change was announced in the judging program, the exhibitors may withdraw their entries up to one-half hour before the start of any **regular** conformation judging at the event. If the notice of change was not in the judging program, a notice must be posted in a prominent place within the event precincts and at the ring and withdrawals may be requested up to any time before the start of judging of that breed.

---

## Records

The superintendent's responsibilities include receiving entries before the event, scheduling judging, collecting judges books, submitting marked catalogs after the event, and keeping records of all procedures and deadlines on each event.

The superintendent should furnish the club with a detailed financial report.

The following must be received by the AKC's Event Operations Department within seven days after the event has been held:<sup>12</sup>

- [Report of Dog Show or Obedience/Rally Trial](#) form, filled out completely with the results of the show. This form must be signed by the Superintendent or Show Secretary.
- The appropriate **Recording and Event Service Fee** accompanies the Report of Dog Show or Obedience/Rally Trial form. When this recording and event service fee is calculated, it does not include withdrawals (usually for a change of judge). Should this be the show secretaries 9<sup>th</sup> event a \$10.00 secretary fee is also required. Special attractions, Junior Showmanship, sweeps, futurities, brace/team, non-regular classes and multi-dog classes are not included in calculating the recording fee. Combined specialties or clusters, must submit individual Report of Dog Shows or Obedience/Rally Trial for all the clubs; a breakdown for each breed/variety in each

---

<sup>10</sup> [Rules Applying to Dog Shows](#), Chapter 11, Section 6

<sup>11</sup> [Rules Applying to Dog Shows](#), Chapter 7, Sections 8, 9

<sup>12</sup> [Rules Applying to Dog Shows](#), Chapter 17, Sections 2

show/trial and an itemization of the amount to be applied to each club must be included with the report.

- A legibly **marked catalog** with all absentees, placements, awards, reasons for withheld awards. Judge substitutions should be marked on the catalog headlines. Reasons for excusals or disqualification's must be shown. This information must be transferred accurately from the judges books. Any printing errors reported to the superintendent or show secretary at the show must be corrected in the marked catalog. **An electronically marked catalog is acceptable.**<sup>13</sup>
- All **Judges Books**. All judging substitutions must be noted on the cover of the judges' books. While the judge is still on the grounds, all books should be checked, allowing for the immediate correction of errors. The judge must initial any errors noted, when corrected. If a judge discovers an error after the day of the show, he should be instructed to submit his corrections in writing to the AKC's Event Operations Department immediately.

## Electronic Transmission of Show Results

A licensed superintendent is required to transmit the results of shows and obedience trials to the AKC electronically.<sup>14</sup>

---

## Superintendents' Contracts

When the club signs a contract for superintendent or show secretary services, it should be sure that all its needs for the event are provided for. All obligations of both parties must be clearly stated and explained, and all expenses must be enumerated in detail. The club must specify in writing all equipment, supplies and personnel it expects the superintendent to provide.

The club must consider its own welfare and financial well being when evaluating a contract. Neither the superintendent nor the club may be held to any agreement that is not detailed in a written contract.

The superintendent is also responsible to AKC. Superintendents share responsibility with the club to ensure that AKC rules, regulations and policies are strictly followed.<sup>15</sup>

---

<sup>13</sup> Rules Applying to Dog Shows, Chapter 14, Section 8

<sup>14</sup> AKC Board Policy, May 2008

<sup>15</sup> Rules Applying to Dog Shows, Chapter 9, Section 10

## Services Furnished by the Superintendent

### Expertise

The superintendent has knowledge of AKC rules, regulations and procedures, and the experience from putting on many shows and trials.

### Printing

Official documents must be printed for every event, including the premium list, judging program and catalog.

The club, through the superintendent or show secretary, must coordinate the submission of material to the printer by their deadlines. Each document must contain specific information and be prepared in the acceptable format. A club should be sure that its printer knows all the requirements for printing AKC documents. Be very specific as to the exact number of each document required and additional items to be printed.

The club should check with the superintendent about whether additional items are needed. Other printing services a superintendent may provide include admission tickets, posters, directional signs, parking stickers, and lunch passes.

The superintendent can provide other event items such as judge's books; ribbons; badges for the committee, judges, stewards, etc.; and armbands.

### Mailing

The superintendent maintains address lists of prospective exhibitors and is able to handle all required mailings.

### Equipment

The physical layout of an event requires the use of a great deal of equipment. The superintendent may provide or arrange for:

- Mats, examination tables, ramps
- Ring dividers, numbers, placement markers
- Exercise pens, sawdust, clean-up supplies
- Tables and chairs
- Obedience/Rally equipment
- Tenting
- Scales and measuring wickets
- Signs
- Banners
- Benching



The club should check with the superintendent for any additional equipment needs.

## Services Furnished by the Club

### Premium List Information

Complete premium list information must be sent to the superintendent by their deadline. The deadlines set by the superintendent are calculated so that the AKC's rules are satisfied.

### Proofreading

**The club must carefully proofread all material sent to them by the superintendent. The club is ultimately responsible for all errors in premium lists.**

### Event Site

The club must provide the superintendent with the event layout and obtain access to the site for them prior to the event. The superintendent must also be advised of any additional requirements or restrictions imposed by the site management.

The club must provide accurate directions to the event site. It is recommended that these be included in both the premium list and judging program.

---

## Package Contracts - Superintending Services

A club can use the services of a show secretary, and contract with a superintendent to handle the printing and mailing of all official documents for the show. Under this arrangement, the superintendent could also provide many of the supplies needed.

The show secretary has the responsibility of enforcing AKC rules on the day of the show, and preparing records for the AKC.

The options for receiving entries are:

- The entries could be received by the show secretary, then forwarded to the superintendent for preparation of the judging program and catalog.
- The show secretary could be named in the premium list with an address other than the show secretary's (e.g., John Doe, Show Secretary; c/o Doug Ljungren Dog Shows, P. O. Box...). The superintendent would be acting as the club's agent, with the show secretary bearing the full responsibility for handling all entries.



# 12: Event Committee Hearings

<b>The Event Committee</b> .....	<b>12-2</b>
The Hearing Committee .....	12-2
Conducting the Hearing .....	12-3
<b>The Hearing Report</b> .....	<b>12-4</b>
<b>The Accused</b> .....	<b>12-4</b>

Event Committee hearings are governed by the rules set forth in Dealing with Misconduct. The following information presents the highlights from this booklet. Questions concerning Committee Hearings may be directed to the AKC's Compliance Department.

A copy of Dealing with Misconduct **must** be available to the complainant, the accused, and each member of the hearing committee at the event.

Incidents of misconduct should be managed with impartiality, orderliness in the procedures followed and fairness in obtaining testimony from witnesses and the accused.

---

## The Event Committee

It is the duty of the Event Committee, not of the AKC, to deal initially with acts of alleged prejudicial conduct which occur during or in connection with a club's event.<sup>1</sup> Prior to the show, it is imperative that all members of the Event Committee thoroughly review the Dealing with Misconduct booklet.

The Event Committee should advise the AKC Executive Field Representative of the charges and when the Representative is available, he/she should be present for the hearing. The Representative will advise all parties about proper procedures.<sup>2</sup>

The Event Committee should plan a location where a hearing could be held. The location should afford the privacy needed - removed from the immediate mainstream of activities yet easily accessible to all parties involved in the hearing.

An Event Committee itself may prefer charges of prejudicial conduct against anyone. Charges do not have to be made by someone directly involved in the incident.

A preliminary investigation is made by the Event Committee to determine whether the allegation(s), if proven, would constitute conduct prejudicial to the best interests of the sport of purebred dogs or to dog shows. If not, the matter can be dismissed without a hearing.

## The Hearing Committee

A hearing committee should consist of at least five individuals listed in the premium list as members of the Event Committee. A minimum of three individuals must be available for a hearing. If three committee members are unavailable due to conflict of interest, other club members

---

<sup>1</sup> Dealing With Misconduct, Section II Paragraph 1

<sup>2</sup> Dealing With Misconduct, Section V Paragraph 1

may be substituted. All committee members must be members of the event-giving club.<sup>3</sup>

A witness cannot serve as a member of the committee. Committee members must excuse themselves if they feel that they could not be impartial to the proceedings, or if they expect to offer testimony for or against the accused.

Conflicts of interest can include, but are not limited to:<sup>4</sup>

- An immediate family member will appear as a witness in the hearing
- A personal or business relationship with the accused or complainant exists
- The inability to be impartial

## Conducting the Hearing

The Dealing with Misconduct booklet outlines in chronological order the steps to be taken to ensure a speedy and fair hearing. The Dealing with Misconduct guidelines, pp. 13-26 – 13-27, help to assure that the committee follows the correct procedure. The committee should fill out the required Procedural Checklist form during the hearing rather than after the hearing is finished.

**If the outcome of the hearing requires disciplinary action, the committee must carry out its responsibilities according to the Charter and Bylaws of the American Kennel Club.**

There are instances when Event Committees unintentionally infringe upon the rights of an accused, providing them with grounds for an appeal and the AKC's reversing the committee's decision. An Event Committee that acts judiciously should expect that its action will be supported by the AKC.

Attempts must be made to contact the accused if the committee learns that the accused has left the show grounds before being advised of the charges. The committee must write to the accused if his/her whereabouts are known, notifying them that charges will be heard, and of the location and time of the hearing, and of their rights. Notice of such hearing must include the specifics of the charge to be heard, and the accused must be provided an opportunity to respond to the charge in writing in the event they are unable to attend the hearing.

If the committee succeeds in contacting and notifying the accused, the hearing may be held at the show, after the close of the show, or the following day.

---

<sup>3</sup> Dealing With Misconduct, Section III Paragraph 1

<sup>4</sup> Dealing With Misconduct, Section III, Paragraph 2

If the accused fails to appear after having been advised of the charges preferred, the nature of the charges, and the time and location of the hearing, the committee should hold the hearing, weighing the testimony of all witnesses and reaching its conclusions as if the accused had been present.<sup>5</sup>

If the committee finds the accused guilty, the accused must be notified by registered or certified mail.

---

## The Hearing Report

A report of the incident, the completed Procedural Checklist, and the committee's conclusion must be included in the Report of Dog Show or Obedience/Rally Trial submitted to the AKC following the event. The accused is entitled to a copy of the report.

The AKC expects the report filed on the record of the hearing to be comprehensive. The report should detail the incident and the charges, and provide a summary of the testimony of all witnesses.

The club must keep accurate records of the hearing. The written record of the proceedings should support the decision reached by the Committee.

If the accused failed to appear at the hearing that fact must be noted in the report and any attempts to contact the accused must be included in the report.

---

## The Accused

The accused must be:

- Advised of his/her rights in the matter, namely that they have enough time to prepare a defense, and gather witnesses, and that he/she may question witnesses and make a statement at the hearing. Neither the complainant nor the witnesses have the right to remain in the hearing, or to question the accused or other witnesses.
- Advised of the nature of the charges, specifically, the offense or conduct alleged to have been prejudicial.
- Advised of where and when the hearing committee meeting will be held, giving the accused reasonable time to prepare for it.
- Given an opportunity to confront his/her accusers, to hear the testimony of all witnesses against him/her, and to cross-examine such witnesses.
- Permitted to testify on his/her own behalf.
- Allowed to present witnesses in his/her defense.

---

<sup>5</sup> Dealing With Misconduct, Section VII, Paragraph 1

The accused may have an attorney present to advise, but not to speak for or officially represent him/her. The hearing may not be delayed so that the accused may get an attorney.<sup>6</sup>

---

<sup>6</sup> Dealing with Misconduct, Section VI, Section IX paragraph 4



# AKC Show/Trial Manual

## 13: Appendix

### Appendix A: Address and Telephone Directories

AKC Telephone Directory .....	13-4
Licensed Superintendents .....	13-6
Miscellaneous Addresses .....	13-8
Dog Show Photographers.....	13-9
Stewards' Organizations .....	13-11
Tenting Companies.....	13-12

### Appendix B: Checklists

Event Checklist .....	13-14
Specialty Club Obedience/Rally Cluster Checklist.....	13-20
Use of Motorized Vehicles at AKC Events and the ADA .....	13-22
Americans with Disabilities Compliance Checklist.....	13-23
Dealing with Misconduct .....	13-26
Site Inspection Checklist.....	13-28

### Appendix C: Reference

Corresponding Date Table.....	13-32
Official AKC Titles for Catalog .....	13-34
Class Divisions .....	13-37
Cluster Site Guidelines .....	13-42
Cluster Site Inspection Guidelines .....	13-43
Judging Ramp Specifications.....	13-47
Training Collars.....	13-48
Site Layouts .....	13-49

### Appendix D: Example Correspondence and Form

Event Financial Planning Sheet.....	13-55
Host Club (Permissions) Letter .....	13-56
Judging Availability Inquiry Letter .....	13-57
Judging Confirmation Letter.....	13-58
Judge's Contract.....	13-59
Hospitality: Judges Information Sheet .....	13-60
Dog Show Photography Agreement .....	13-61
Letter for Radio Coverage .....	13-62
Press Release for Print Media .....	13-63

Dogs in Unventilated Vehicles .....	13-64
Crate Identification Labels.....	13-67
<b>Appendix E: Sample Show Documents</b>	
Judges Books .....	13-70





---

## Appendix A: Address and Telephone Directories

<b>AKC Telephone Directory</b> _____	<b>13-4</b>
<b>Licensed Superintendents</b> _____	<b>13-6</b>
<b>Miscellaneous Addresses</b> _____	<b>13-8</b>
Liability and Accident Insurance .....	13-8
<b>Dog Show Photographers</b> _____	<b>13-9</b>
East .....	13-9
South .....	13-9
Midwest.....	13-9
West .....	13-10
<b>Stewards' Organizations</b> _____	<b>13-11</b>
East .....	13-11
South .....	13-11
Midwest.....	13-11
West .....	13-11
<b>Tenting Companies</b> _____	<b>13-12</b>
East .....	13-12
South .....	13-12
Midwest.....	13-12

---

# AKC Telephone Directory

**American Kennel Club**  
8051 Arco Corporate Drive,  
Suite 100  
Raleigh, NC 27617-3390

<b>Main Number</b> .....	<b>(919) 816-3600</b>
<b>Web site</b> .....	<b>www.akc.org</b>
<b>AKC Reunite</b> .....	<b>found@akc.org</b>
General.....	(800) 252-7894
Fax .....	(919) 233-1290
<b>Club Education/AKC Booth</b> .....	<b>publiced@akc.org</b>
General.....	(919) 816-3722
Fax .....	(919) 816-4275
<b>Club Relations</b> .....	<b>clubrelations@akc.org</b>
New Clubs .....	(212) 696-8211
Fax .....	(212) 696-8309
<b>Customer Service</b> .....	<b>info@akc.org</b>
Subscriptions, Books and Videos.....	orderdesk@akc.org
General.....	(919) 233-9767
Fax .....	(919) 816-3740
<b>DNA Operations</b> .....	<b>dna@akc.org</b>
General.....	(919) 816-3508
Fax .....	(919) 816-4255
<b>Event Operations (Application and Records Processing)</b> .....	<b>eventplans@akc.org</b>
Event Records (Conformation/Obedience) .....	awards@akc.org
Application Processing - Conformation/Obedience.....	(919) 816-3579
Event Records.....	(919) 816-3538
Performance Events/Tracking.....	(919) 816-3908
Agility/Rally .....	(919) 816-3725
CGC.....	919) 816-3637
CGC.....	<b>cgc@akc.org</b>
CGC (fax).....	(919) 816-4203
Fax - Application Processing .....	(919) 816-4220
Fax - Event Records.....	(919) 816-4220
<b>Event Operations, Conformation Rules and Policy</b> .....	
Alan Slay, Director.....	(919) 816-3806
E-mail .....	als@akc.org
Bri Tesarz, Programs Manager .....	(919) 816-3514
E-mail .....	glt@akc.org
Fax .....	(919) 816-4265
<b>Foreign Registration</b> .....	
General .....	(919) 816-3539
Fax .....	(919) 816-4235
<b>GAZETTE</b> .....	<b>gazette@akc.org</b>
Editorial.....	(212) 696-8295
Fax .....	(212) 696-8239
Advertising.....	(212) 696-8260
Fax .....	(212) 696-8217

<b>Handlers Department</b> .....	<b>handlers@akc.org</b>
General .....	(919) 816-3884
Fax .....	(919) 816-4225
<b>Inspections and Investigations</b> .....	
General .....	(919) 816-3552
Fax .....	(919) 816-4245
<b>Judges Education (Conformation)</b> .....	<b>judgesed@akc.org</b>
General .....	(919) 816-3562
Fax .....	(919) 816-4225
<b>Judging Operations (Conformation)</b> .....	<b>judgingops@akc.org</b>
General .....	(919) 816-3570
Fax .....	(919) 816-4225
<b>Junior Showmanship</b> .....	<b>juniors@akc.org</b>
General .....	(919) 816-3816
Fax .....	(919) 816-3770
<b>Miscellaneous Class/Rare Breeds/Foundation Stock Service</b> .....	<b>fss@akc.org</b>
General .....	(919) 816-3813
Fax .....	(919) 816-3770
<b>Obedience/Tracking/CGC/Agility (Rules, Regulations, Policy)</b> .....	<b>obedience@akc.org</b>
E-mail .....	tracking@akc.org
E-mail .....	cgc@akc.org
E-mail .....	agility@akc.org
General .....	(919) 816-3575
Fax .....	(919) 816-4204
<b>Order Desk/Fulfillment</b> .....	<b>orderdesk@akc.org</b>
General .....	(919) 233-9767
Fax .....	(919) 816-3627
<b>Performance Events (Rules, Regulations, Policy)</b> .....	<b>fieldtrials@akc.org</b>
E-mail .....	coursing@akc.org
E-mail .....	earthdog@akc.org
E-mail .....	herding@akc.org
E-mail .....	huntingtest@akc.org
General .....	(919) 816-3908
Fax .....	(919) 816-3905
<b>Registration</b> .....	<b>registration@akc.org</b>
General .....	(919) 233-9767
<b>Sport Services (Points, ILP No., Kennel Names, Impure Breeding)</b> .....	<b>awards@akc.org</b>
General .....	(919) 816-4593
Fax .....	(919) 816-3770
<b>Weekend Club Hotline</b> .....	<b>(800) 252-7894</b>

---

## Licensed Superintendents

To superintend events held under American Kennel Club rules, an individual must hold a license from AKC. The following is a list of Annually Licensed Superintendents.

**Baray Event Services.....(360) 755-7086**

Shelia Raymond  
Mailing address: P O Box 508, Burlington, WA 98233  
Business address: 113 E Fairhaven Ave., Burlington, WA 98233  
Fax.....(360) 755-2248  
E-Mail.....dogshows@barayevents.com  
Web site..... [www.barayevents.com](http://www.barayevents.com)

**Foy Trent Dog Shows ..... (573) 687-2101**

Foy Trent  
PO Box C Sturgeon MO 65284  
Fax ..... (888) 685-8989  
E-mail ..... [mail@foytrentdogshows.com](mailto:mail@foytrentdogshows.com)  
Web site ..... <http://www.foytrentdogshows.com/>

**Jack Bradshaw Dog Shows ..... (323) 727-0136**

Jack Bradshaw  
Mailing address: P O Box 227303, Los Angeles, CA 90022-0178  
Business address: 5434 E Olympic Boulevard, Los Angeles, CA 90022  
Fax ..... (323) 727-2949  
E-mail ..... [mail@jbradshaw.com](mailto:mail@jbradshaw.com)  
Web site ..... [www.jbradshaw.com](http://www.jbradshaw.com)

**Jack Onofrio Dog Shows, L.L.C..... (405) 427-8181**

Mailing address: P O Box 25764, Oklahoma City, OK 73125-0764  
Business address: 3401 NE 23<sup>rd</sup> Street, Oklahoma City, OK 73121-2447  
Fax ..... (405) 427-5241  
Oregon office..... (503) 239-1080  
Mailing address: P O Box 4660, Portland, OR 97208-4660  
Business address: 2710 SE 50<sup>th</sup> Avenue, Portland, OR 97206-1538  
E-mail ..... [mail@onofrio.com](mailto:mail@onofrio.com)  
Web site ..... [www.onofrio.com](http://www.onofrio.com)

**MB-F, Inc..... (336) 379-9352**

Mailing address: P O Box 22107, Greensboro, NC 27420-2107  
Business address: 620 Industrial Avenue, Greensboro, NC 27406  
Fax ..... (336) 272-0864  
California office..... (510) 724-4716  
Florida office..... (352) 796-1816  
Michigan office ..... (248) 588-5000  
Oregon office..... (336) 379-9352  
E-mail ..... [mbf@infodog.com](mailto:mbf@infodog.com)  
Web site ..... [www.infodog.com](http://www.infodog.com)

**Rau Dog Shows, Ltd.** .....(610) 376-1880  
Kathleen Berkheimer  
Mailing address: P O Box 6898, Reading, PA 19610-0898  
Business address: 235 S 2<sup>nd</sup> Avenue, West Reading, PA 19611  
Fax .....(610) 376-4939  
E-mail ..... info@raudogshows.com  
Web site ..... [www.raudogshows.com](http://www.raudogshows.com)

**Roy Jones Dog Shows, Inc.**.....(260) 925-0525  
Kenneth A. Sleeper  
Mailing address: P O Box 828, Auburn, IN 46706-0828  
Business address: 1105 W Auburn Drive, Auburn, IN 46706  
Fax .....(260) 925-1146  
E-mail ..... rjds@royjonesdogshows.com  
Web site ..... [www.royjonesdogshows.com](http://www.royjonesdogshows.com)

---

## Miscellaneous Addresses

### Liability and Accident Insurance

**Equisure Inc** ..... **(800)-752-2472**  
Phone ..... (303)-614-6961  
Fax..... (303)-614-6967  
13790 E. Rice Place  
Suite 100  
Aurora, CO 80015

---

# Dog Show Photographers

The following photographers requested a listing in the AKC Show/Trial Manual. You may find other qualified photographers in your area.

## East

### **A-N Productions .....(518) 885-1927**

Tom Nutting  
PO Box 2350, Malta, NY 12020  
Email ..... [tom@nutting.net](mailto:tom@nutting.net)  
Website ..... [www.nutting.net](http://www.nutting.net)

### **Ashbey Photography.....(610) 681-4968**

John L. Ashbey  
P.O. Box 468, Gilbert, PA 18331  
Fax: .....(610) 681-6469  
Email: ..... [jashbey@ptd.net](mailto:jashbey@ptd.net)  
Web site: ..... [www.johnashbey.com](http://www.johnashbey.com)

### **Dog Show Photography.....(301) 865-0855**

Tom DiGiacomo  
6820 Cherry Tree Ct, New Market, MD 21774  
Email: ..... [tom@dogshowphoto.com](mailto:tom@dogshowphoto.com)  
Website ..... [www.dogshowphoto.com](http://www.dogshowphoto.com)

### **The Standard Image .....(603) 357-7086**

Fritz Clark  
P.O. Box 74, Gilsum, NH 03448  
Fax: .....(603) 357-7086  
Email: ..... [fritz@fritzclark.com](mailto:fritz@fritzclark.com)

## South

### **McNabb, Bryan .....(704) 279-0859**

P.O. Box 780, Granite Quarry, NC 28072  
Email ..... [remington70@windstream.net](mailto:remington70@windstream.net)

### **Sosa Photography.....(985) 845-4562**

Luis Sosa  
P.O. Box 159, Mandeville, LA 70470-0159  
Email ..... [sosaphoto@charter.net](mailto:sosaphoto@charter.net)  
Website ..... [www.sosaphoto.biz](http://www.sosaphoto.biz)

## Midwest

### **Robert Skibinski Photography .....(219) 662-7725**

Robert Skibinski  
10766 Hanley Street., Crown Point, IN 46307  
Email ..... [skibinski2@aol.com](mailto:skibinski2@aol.com)

## West

**Callea Photo ..... (360) 426-2172**

Meg Callea

200 E. Tramac Place, Shelton, WA 98584-8880

Fax: ..... (360) 426-0139

Email: ..... [calleafoto@aol.com](mailto:calleafoto@aol.com)

**FlashKatPhotos..... (760) 751-2757**

Kit Rodwell

P.O. Box 300400, Escondido, CA 92030-0400

Fax ..... (760) 751-2761

Email ..... [flashkatphotos@aol.com](mailto:flashkatphotos@aol.com)

**Holloway Photo ..... (951) 682-3164**

Vicki Holloway

2525 Thayer Court, Riverside, CA 92507

Email ..... [Hollowayphoto@me.com](mailto:Hollowayphoto@me.com)

Website ..... [www.hollowayphoto.com](http://www.hollowayphoto.com)

**O'Brien Photography ..... (916) 988-5610**

Ken O'Brien & Sharlene O'Brien

P.O. Box 1175, Folsom, CA 95763

Fax ..... (916) 988-5610

Email ..... [obrienphotography@att.net](mailto:obrienphotography@att.net)

**Steven Ross Photo ..... (360) 864-4462**

Steve Ross

P. O. Box 1145, Chehalis, WA 98532

Email: ..... [steverossphoto@toledotel.com](mailto:steverossphoto@toledotel.com)



---

## Stewards' Organizations

The following is a list of several Stewarding Organizations who requested a listing in the AKC Show/Trial Manual. You may find other qualified organizations in your area.

Be sure to inquire if a fee will be charged to the Club.

### East

**Eastern PA Stewards Club**.....[www.easternstewards.org](http://www.easternstewards.org)

**Mid-Atlantic Stewards Association** ..... [www.mid-atlanticstewards.com](http://www.mid-atlanticstewards.com)

**Stewards Club of America** ..... (914) 374-2708

Rose Robischon

1100 Ridgebury Rd, New Hampton, NY 10958

### South

**Mission City Stewards Club** .....[www.mcsc.homestead.com](http://www.mcsc.homestead.com)

**Southeastern Professional Stewards' Association, Inc.** ..... (321) 269-0555

Elizabeth Page

PO Box 802, Mims, FL 32754

**Stewards Club of Dallas** ..... [www.stewardsclub.org](http://www.stewardsclub.org)

### Midwest

**Oklahoma Mid-American Ring Stewards**..... (417) 529-8310

Ms. Erma Susedik

### West

**New Mexico Stewards Association**.....

PO Box 7070, Albuquerque, NM 87194

**Professional Stewards Association of Northern California**

..... [www.sites.google.com/site/professionalstewardsca/](http://www.sites.google.com/site/professionalstewardsca/)

**Stewards Club of Arizona** ..... [www.stewardsclubofarizona.com](http://www.stewardsclubofarizona.com)

---

# Tenting Companies

## East

- Ace Canvas & Tent**..... (800) 456-9894  
85-5 Air Park Drive, Ronkonkoma, NY 11779..... [www.acecanvasandtent.com](http://www.acecanvasandtent.com)
- Jamestown Awnings, Inc.** ..... (716) 483-1435  
289 Steele Street, Jamestown, NY 14701 ..... [www.jamestownawning.com](http://www.jamestownawning.com)
- L & A Tent Rentals** ..... (609) 584-0054  
180 Whitehead Road, Trenton, NJ 08691..... [www.latents.com](http://www.latents.com)
- Yankee Tents**..... (413) 367-2210  
55 Swamp Road, Montague, MA 01351 ..... [www.yankeetents.com](http://www.yankeetents.com)

## South

- Apex Holiday Tents & Bleachers**..... (941) 723-1822  
2017 Manatee Avenue W, Bradenton, FL 34205 ..... [www.apexholidaytents.com](http://www.apexholidaytents.com)
- Kirby Rental Center**..... (407) 422-1001  
411 Hames Avenue, Orlando, FL 32805-1512..... [www.kirbytent.com](http://www.kirbytent.com)
- Southern Tent Company**..... (866) 944-8194  
P. O. Box 6, Courtland, VA 23837..... [www.southerntentco.com](http://www.southerntentco.com)

## Midwest

- Aable Rents** ..... (216) 692-9800  
1365 Chardon Road, Cleveland, OH 44117..... [www.aablerents.com](http://www.aablerents.com)
- Dial Tent & Awning** ..... (989) 793-0741  
5330 Davis Road, Saginaw, MI 48604-9497..... [www.dialtentandawning.com](http://www.dialtentandawning.com)



# AKC Show/Trial Manual

---

## Appendix B: Checklists

<b>Event Checklist</b> _____	<b>13-14</b>
<b>Specialty Club Obedience/Rally Cluster Checklist</b> __	<b>13-20</b>
<b>Use of Motorized Vehicles at AKC Events and the ADA</b>	<b>13-22</b>
<b>Americans with Disabilities Compliance Checklist</b> __	<b>13-23</b>
<b>Dealing with Misconduct</b> _____	<b>13-26</b>
<b>Site Inspection Checklist</b> _____	<b>13-28</b>

---

## Event Checklist

The following checklist is a reference for use when planning an event. By referring to all applicable AKC publications and recommendations outlined in the Show/Trial Manual, the entire event process will be simplified. The AKC Staff is available to provide assistance in all areas.

### At Least One Year Prior to the Show

- Judges should be selected and invitations extended as far in advance as possible. As soon as the judges reply, the panel should be finalized, and confirmation of each judge's specific assignment should be sent. This method may be used for part of the panel, as show chairs should keep in mind that judges are approved monthly for additional breeds and provisional judges are always forthcoming.
- Extend invitations to any specialty clubs that you may wish to hold their specialties with your club or support their breed entry at your event. Their suggestions for breed judges should also be requested at this time.
- If a Superintendent is to be employed a contract should be requested, reviewed and signed.
- Contact and secure the services of the Show Photographer.
- A final contract should be signed with the management of the facility or grounds where the event is to be held, and any required binder for the site should be paid.
- The date application and event site layout (if applicable) should be submitted to the AKC for approval. Rules require submission 18 weeks prior to closing date for entries.
- The panel of judges should be submitted to the AKC for approval as soon as it is finalized. Rules require submission 18 weeks prior to closing date of entries.

### Permit Judges

Published monthly in the Secretary's Page of the AKC Gazette and listed in italics in the annual Judge's Directory.

Recommended guidelines:

- fewer than 1,000 dogs, minimum of four permit judges
- 1,000 to 2,000 dogs, minimum of six permit judges
- more than 2,000 dogs, minimum of eight permit judges

## Visiting (Foreign) Judge

Requests should be submitted to the AKC at least six months before closing date to allow time for processing and approval.

- Indicate judge's exact assignment to the AKC.
- First AKC assignment: must indicate how the club learned of the judge, background, anyone personally familiar with judge and if fluent in English.

## Judging Conflicts

Breed -- 200 miles and 30 days (does not apply to non-regular classes or tracking)

Obedience -- 100 miles and 30 days for two all-breed trials

- No conflict for Specialties if different breeds
- No conflict for Specialty and All-breed
- No conflict for Group shows/ Group clubs

- All members of the Event Committee should be named and assigned tasks.
- The Trophy and Advertising Committee Chairs should be aware of their duties and should begin soliciting donations and advertising.
- The Chief Steward should be selected. If a Steward's Club is to provide the stewards, contact that group at least one year prior to the event.

## At Least Six Months Prior to the Show

- Review the advertising copy that is to be distributed for the event.
- Contact one of the dog food companies for arrows, posters, signs, tickets, etc.
- Close out trophy solicitations and place orders for ribbons and trophies.
- Set prices on admissions, catalogs and concessions.
- Have all premium list copy sent to the superintendent or printer. Decide how many premium lists are to be printed.
- Confirm that arrangements for all equipment for the event have been made. Check contract with superintendent, if applicable, to verify what is, and is not, being provided.
- Finalize judges' hotel reservations.
- Arrangements should be made with the veterinarian. This should be in writing.
- The catering arrangements should be finalized.

- Secure the services of a photographer, if not already done.
- Secure Rain Insurance if applicable and if desired.
- Secure the return of any multiple-win trophies. Remember to have them cleaned and/or engraved.
- Arrange for portable sanitary facilities if necessary.

### **At Least Three Months Prior to the Show**

- Close out catalog advertising and forward all advertising received to the superintendent or printer.
- Inform printer or superintendent of number of catalogs to be printed. (This may be an estimate with the final figure determined after entries close.)
- If possible, find out who the specific individual superintendent assigned to your event will be.
- Arrange for a clean-up crew.
- Notify the local authorities of your event date, indicating expected peak traffic hours.
- Make arrangements for security and traffic control personnel.

### **Six Weeks Prior to the Show**

- Ensure that premium lists have been mailed.
- Order chairs. Base the number on previous event requirements.
- Check with the caterer about breakfasts / lunches for all officials and invited guests and give an estimate of the number to be served based upon last year's event. Arrange for early morning set-up to accommodate exhibitors.
- Make arrangements for an adequate sound system.
- Notify the local press and media of the event to be held. Stress that spectators must leave their own (unentered) dogs at home.
- Prepare a final list of stewards.
- Ensure there will be electricity available, if possible.
- Distribute directional arrows and posters to the Grounds Committee.
- Review each committee's assignment and finalize reporting times.

- Arrange for telephone service at the event site.
- Check on arrangements for drinking water.
- Arrange for emergency medical service, if required.
- Arrange for towing services in case they are needed.
- Secure volunteers for various duties as needed.

### **Three Weeks Prior to the Show**

- Close entries.
- Sort and break down entries as soon as possible.
- Finalize how many Best of Breed and Variety prizes and Class ribbons will be needed.
- Prepare the catalog.
- Prepare a judging schedule and assign rings. Advise Chief Ring Steward of entry.

### **One Week Prior to the Show**

- See that judging programs and identification tickets have been mailed to exhibitors, judges, the chief steward and the AKC.
- Ensure that grounds will be ready; grass mowed, water available, etc.
- Check with the Hospitality Chair that all last-minute reservations and accommodations have been provided.
- Check to see that all necessary equipment will be available for the show.
- Arrange for delivery of catalogs.
- Check with the Treasurer to see that an ample number of checks will be available and that there will be sufficient change for the gate, catalog and parking committees.

### **Two Days Before the Show**

- Arrange for the placement of tents and rings.
- Arrange for the placement of concessions.
- Oversee the set-up of rings, tents and chairs in their proper locations.

## Day Before the Show

- Set up exercise pens.
- Supervise the concessionaires setting up.
- Make one last check of the show site.
- Check with all key personnel as to reporting time the next day.

## Day of the Event

- Arrive at least 2 hours before judging.
- Check in workers and provide any last-minute instructions.
- Check out arrangements with caterer. Are they properly positioned on the grounds for the convenience of the exhibitors?
- Check in judges, stewards, and veterinarian if on site, volunteer and hired personnel. Gate and parking crews should be on station two hours before the event begins.
- Colors and national anthem are ready.
- Supply the chief steward a sufficient number of luncheon tickets; the balance of tickets to be used for the judges, superintendents, club members and others.
- Have Hospitality check the rings and judges' needs throughout the day.
- Check and maintain all rings on schedule. Consult with superintendent and Chief Steward about keeping abreast of judging schedule.
- Have available latest copies of Rules Applying to Dog Shows, The Complete Dog Book, Show/Trial Manual, Dealing with Misconduct, Rules Applying to Registration and Discipline, Conformation Junior Showmanship Regulations, Guidelines for Judging Juniors in Conformation, Juniors in Performance Events, and Obedience Regulations, Obedience Judges Guidelines, The Steward in Obedience, Rally Regulations, Rally Judges Guidelines, The Steward in Rally, if applicable.
- Circulate to obtain objective and knowledgeable reactions to the show from exhibitors.
- Settle all misunderstandings, whenever they occur.
- Communicate with committees throughout the day, and approve payment of the judges.
- Confer with superintendent and the Executive Field Representative(s) about possible improvements for future events.



- Before leaving the site, ensure that all equipment is accounted for and that grounds are properly reconditioned.

### **After the Event (If the Club is putting on its own)**

- The catalog must be properly marked, including corrections of printing errors, absentees and explanations where there have been excusals, disqualification or awards withheld.
- The marked catalog and judges books must be sent to the AKC's Event Operations Department to reach that office within seven (7) days of the Show/Trial. The Recording Fee and Service Fee must also be calculated and submitted with the Report of Dog Show or Obedience/Rally Trial form to the AKC's Event Operations Department.

Event Operations Department  
American Kennel Club  
(919) 816-3538

**Letters can be sent to:**  
PO Box 900051  
Raleigh, NC 27675-9051

**Packages can be sent to:**  
8051 Arco Corporate Drive,  
Suite 100  
Raleigh, NC 27617-3390

- Meet with committee chairs and AKC Executive Field Representative for an evaluations session to discuss possible changes and improvements to be made for future events.

---

## Cluster Checklist

This checklist should be used in conjunction with the Event Checklist, 13-14 to 13-19.

- Host or Coordinating Club names a Club Coordinator. This is an official position within the Cluster Committee.
- Coordinator meets with all Specialty Clubs who wish to participate in the cluster.
- Participating clubs decide on judge(s) to be used for classes.
- Participating clubs agree on the order of judging by breed.
- Each club submits an Application for Show/Trial to the AKC for its show date(s).
- Each club submits its Judges Panel, including obedience and rally, to the AKC.
- Coordinator develops a rough-planning schedule based on entries from previous years.
- Coordinator meets with Show Chairs, Obedience/Rally Chairs, and show secretaries/superintendents of participating clubs to discuss hypothetical scheduling. This will minimize confusion at the time entries close.
- Entries close on the common closing date.
- Coordinator sends all show secretaries, superintendents, show chairs and Obedience/Rally Chairs an Obedience/Rally Judging Program for their specific breeds, and a Master Judging Program for obedience and rally.
- Show secretaries and/or superintendents mail a Judging Program to each exhibitor.
- Show secretaries and/or superintendents prepare Judges Books for each class for which their breed has an entry.

### Day of the Show/Trial

- Coordinator ensures that there is a minimum of three stewards for each obedience ring, one of whom will be responsible for coordinating ribbons, judges books, and other tasks that are specifically related to a obedience trial.
- The Obedience/Rally Coordinator will deliver trophies, ribbons, armbands, a catalog, and Judges Books for each breed to the appropriate obedience ring. The coordinating club will supply rubber bands and other standard stewards' materials.
- Coordinator provides each participating specialty club with a bill showing its share of the judges' expenses/fees and a separate bill for any other shared/pro-rated expenses.

- Each dog will be judged, and individual scores recorded in the respective breed's judges book for a clustered obedience/rally trial.

For the group exercises, all breeds will be judged in one group. If there are more dogs competing than can be spaced four (4) feet per dog on one side of a ring, some must be judged in another group. The judge will divide the class into equal sections and the group exercise will be judged after each section.

Following completion of group exercises, the judge will complete judges books for all Open B dogs. Ribbons and awards will then be awarded by breed. Cluster Obedience/Rally Coordinator will return judges' books to the appropriate show secretary or superintendent.

- Judging begins for the next scheduled class with the same judge.
- High in Trial, High Combined or other breed-specific special awards are determined and awarded by breed. High Combines does not apply for Rally.

### **Within One Month After the Show/Trial**

- Coordinator meets with all participating clubs for an evaluation session to discuss possible changes for future events.

---

## Use of Motorized Vehicles at AKC Events and the ADA

Clubs, during an event, may restrict the use of motorized vehicles completely or within a set distance from the ring, grooming areas or other areas. However, the event-giving club must comply with the Americans with Disabilities Act (“ADA”) state and local laws. The ADA requires public accommodations, which includes an AKC event, to modify policies, practices or procedures if it is necessary for a disabled individual to have access to the public accommodation if the modification does not fundamentally alter the event. In making a determination as to whether or not a modification of a club policy would fundamentally alter an event, the club must make an individualized assessment with respect to the disability and the accommodation requested. The decision should be reasoned, logical and explainable. The ADA states that public accommodations may not discriminate against an individual in the operation of a place of public accommodation. Individuals with disabilities may not be denied full and equal enjoyment of the goods, services, facilities, privileges, advantages or accommodations offered by the public accommodation. Individuals with disabilities should have equal opportunity to participate and benefit in the most integrated setting. The ADA prohibits inquiries into the existence of a disability.

With respect to the use of a motorized vehicle, the club through its premium list, may specify that motorized vehicles are not permitted on the event site or within a certain distance of a specified area if the club chooses. The club should have a procedure in place for individuals with a disability to request a reasonable modification of the policy. The club may request that exhibitors supply the club with information regarding their disability and the necessity to use a motorized vehicle prior to the event. However, please note that unnecessary inquiries regarding the disability are prohibited. The event-giving club should be prepared to address requests on the day of the event and should not deny the use of motorized vehicles just because the request came on the day of the event. With respect to spectators and the use of motorized vehicles, these requests will most likely have to be addressed on the day of the event.

For additional information on a club’s requirements under the ADA, an ADA compliance checklist is printed in the Show/Trial Manual and is designed to assist clubs in looking at the ADA issues involved with respect to their event. The US Department of Justice has established an ADA hotline 1-800-514-0301 to answer questions regarding the ADA. If a club has a question regarding a specific issue, a club member should call the ADA hotline, being sure to record the particulars of the call, such as name of the individual you spoke with, the date and the advice received. Additionally, the US Department of Justice publishes several pamphlets to assist organizations in complying with the ADA, they include a pamphlet entitled “Accessible Stadiums” which provides good information regarding the issues a club may have in putting on an event. The printed material is available on their web site at [www.ADA.gov](http://www.ADA.gov).

---

# Americans with Disabilities Compliance Checklist

The following checklist will help clubs understand their obligations under the Americans with Disabilities Act as it relates to public accommodations.

## General Requirements for Public Accommodations

- 1) Do you provide individuals with disabilities an opportunity to receive goods and services that is equivalent to that provided to others and is not separate or different?

Yes  No  N/A

- 2) Does your lease allocate responsibilities for ADA compliance in common areas and within the place of public accommodation?

Yes  No  N/A

- 3) Do you have a system for ensuring that accessibility features such as elevators are maintained in working order?

Yes  No  N/A

## Specific Requirements for Public Accommodations

### Removal of Barriers or Provision of Readily Achievable Alternatives:

(Note: Questions 4-12 below are the basic questions you need to ask yourself to determine whether individuals with disabilities have access to your facility and its goods and services. You will need to answer the questions for each of your facilities. The questions are listed below according to the priorities set out in the regulations. **Only a few of the most important features of each element are included in each question. You must refer to Americans with Disabilities Act Accessibility Guidelines (ADAAG) to understand all of the requirements for each element.**)

- 4) Do you have sufficient entrances (one in most buildings; more in larger buildings with more entrances) that are usable by a person using a wheelchair, i.e., among other things, wide, smooth and level or, if not level, equipped with a ramp, curb ramp, elevator or platform lift?

Yes  No  N/A

If not, what corrective actions are needed (e.g. add a ramp; install a platform lift)?

- 5) Does the accessible entrance(s) have an accessible door that, among other things, is at least 32" wide, is not a revolving door or turnstile, and has door hardware usable by individuals with disabilities?

Yes  No  N/A

If not, what corrective actions are needed (e.g. widen the door; install an offset hinge to widen the doorway; eliminate a turnstile or provide an alternate accessible door; install accessible door hardware)?

- 6) Do you have an adequate number of accessible parking spaces for cars that, among other things, are at least 96" wide with an 60" access aisle, and for vans are 96" wide with a 96" access aisle and 98" vertical clearance?

Yes  No  N/A

If not, what corrective actions are needed (e.g. add an accessible space, restripe the parking lot to create spaces)?

- 7) If you provide a passenger loading zone, is it usable by an individual using a wheelchair (i.e. among other things, does it have a wide, firm and level pedestrian aisle and a parallel, level or ramped vehicle pull-up space)?

Yes  No  N/A

If not, what corrective actions are needed (e.g. re-grade the surface, install a curb cut)?

- 8) Do you have an accessible route (i.e. a route that, among other things, is 36" wide, with sufficient clear head room, and curb ramp or ramps where necessary) from parking, passenger loading zones, public transportation stops and streets or sidewalks?

Yes  No  N/A

If not, what corrective actions are needed (e.g. install ramps or curb cuts; remove protruding objects; add detectable warnings; remount signs; add Braille and/or raised lettering to signs; eliminate manholes)?

- 9) Are your halls, aisles and corridors, lobbies and any doors leading to the area(s) where you provide goods and services usable by individuals using wheelchairs?

Yes  No  N/A

If not, what corrective actions are needed (e.g. remove high pile, low density carpeting; fasten carpet edges to the floor; move equipment out of the hallway; install flashing alarm lights)?

- 10) Can an individual using a wheelchair get to the area(s) where goods and services are provided?

Yes  No  N/A

If not, what corrective actions are needed (e.g. rearrange displays, provide accessible seating; widen aisles; reposition shelves)?

- 11) Do you have an adequate number of restrooms usable by individuals using wheelchairs (which have, among other things, wide enough bathroom and toilet stall doors, sufficient maneuvering space, and grab bars)?

Yes  No  N/A

If not, what corrective actions are needed (i.e. install grab bars in toilet stalls; rearrange toilet partitions to increase maneuvering space; insulate lavatory pipes under sinks to prevent burns; install a raised toilet seat; install a full-length mirror; reposition the toilet paper and/or paper towel dispenser(s) in the bathroom)?

12) Are there any other measures that you should take to provide access to your goods and services (e.g. to make telephones or water fountains accessible, for example)?

Yes  No  N/A

If yes, what corrective actions are needed (i.e. lower telephones; add Braille and/or raised markings on elevator control buttons; install an accessible paper cup dispenser at an existing inaccessible water fountain)?

---

## Dealing with Misconduct

**The following is a guideline for handling matters of misconduct arising at or in connection with the AKC Events. The Procedural Checklist - Event Committee Hearings must be completed and sent to the AKC. A Procedural Checklist is included with this manual; one may also be obtained from the AKC Executive Field Representative at the event. The Checklist is also available in the Downloadable Forms section of the AKC website ([www.akc.org](http://www.akc.org))**

### Pre-Hearing

- 1. *Preliminary Investigation.* Investigate all complaints and make a preliminary determination whether, if the alleged conduct is proven true, it was prejudicial to the sport and it occurred at or in connection with the show or trial.
- 2. *Notice of Hearing.* If the preliminary investigation is affirmative, the accused must be advised of:
  - a) The charges including the specific conduct alleged to be prejudicial to the sport:
  - b) Where and when the hearing will be held. (The accused must be given reasonable time to secure witnesses and to prepare.)

### Hearing

- 3. *Introduction.* The Chairperson introduces himself and the members of the committee and designates one member of the committee to keep a record of the proceedings.
- 4. *Advise of Charges.* The Chairperson again advises the accused of the specific charges.
- 5. *Advise of Rights.* The Chairperson advises the accused of these rights:
  - a) To hear, confront and question all witnesses,
  - b) To present witnesses on his own behalf, and
  - c) To testify on his own behalf.
- 6. *Witness List.* The Chairperson shall determine and list witnesses to be called by the Committee and the accused.
- 7. *Unauthorized Persons Excused.* The Chairperson excuses all persons except the Committee, the accused and the witness that is testifying.



- 8. *Witnesses.* The Chairperson shall call and **swear** the witnesses, first those named by the Committee and then those named by the accused. The Chairperson shall ascertain the full name and address of each witness. The Chairperson shall question the witness and then allow the accused to question the witness. (An oath: "Do you swear or promise that you will tell the truth, the whole truth, and nothing but the truth?")
- 9. *Accused Statement.* After all the witnesses have testified, the Chairperson will permit the accused to make a final statement in response to the charges.
- 10. *Close Hearing.* The Chairperson shall then excuse all persons except the Committee. He shall ask the accused to remain available to receive the Committee's decision.

### **Post-Hearing**

- 11. *Findings.* After deliberation and by majority vote, the Committee shall make findings:
  - a) As to whether the charged conduct has been proven.
  - b) Whether such conduct was prejudicial to the best interests of purebred dogs, dog shows, obedience trials, or the AKC, and
  - c) Whether the charged conduct occurred in connection with or during the progress of its show or trial.
- 12. *Decision*
  - a) If the Committee finds that any of the three elements in number 11 have not been proven, it shall dismiss the charges.
  - b) If the Committee finds that all three elements in number 11 have been proven, it shall suspend the accused from all AKC privileges.
- 13. **Notice. After the Committee makes its decision, the Chairperson shall:**

**a) If possible, immediately notify the accused of the Committee's decision and of his immediate suspension, if that was ordered.**

**b) Notify the accused, in writing, by registered or certified mail, of the Committee's decision and his immediate suspension, if that was ordered.**

**c) Send to the Executive Secretary of the AKC, so as to be received within five days, a complete report of the proceedings and a duplicate copy of the notice of suspension sent to the accused.**

---

# Site Inspection Checklist

Site Name and Location: \_\_\_\_\_

Date of Inspection: \_\_\_\_\_

Club/Contact Person: \_\_\_\_\_

## Indoor Site

**Acceptable**      **Unacceptable**

- |                                      |                          |                          |
|--------------------------------------|--------------------------|--------------------------|
| Proper Lighting                      | <input type="checkbox"/> | <input type="checkbox"/> |
| Adequate Ventilation                 | <input type="checkbox"/> | <input type="checkbox"/> |
| Adequate Heating or Air Conditioning | <input type="checkbox"/> | <input type="checkbox"/> |
| Rest Rooms                           | <input type="checkbox"/> | <input type="checkbox"/> |

## Outdoor Site

**Acceptable**      **Unacceptable**

- |   |                          |                          |
|---|--------------------------|--------------------------|
| Adequate Protection from Elements             | <input type="checkbox"/> | <input type="checkbox"/> |
| Adequate Tenting for Expected Entry           | <input type="checkbox"/> | <input type="checkbox"/> |
| Adequate Cover for Judge in Ring              | <input type="checkbox"/> | <input type="checkbox"/> |
| Condition of Grounds                          | <input type="checkbox"/> | <input type="checkbox"/> |
| Portable Toilets                              | <input type="checkbox"/> | <input type="checkbox"/> |
| Provision for Site Clean-Up                   | <input type="checkbox"/> | <input type="checkbox"/> |
| Water   | <input type="checkbox"/> | <input type="checkbox"/> |
| Electricity (optional)                        | <input type="checkbox"/> | <input type="checkbox"/> |
| Parking (must be at least 50' from all rings) | <input type="checkbox"/> | <input type="checkbox"/> |

## All Sites

**Acceptable**      **Unacceptable**

- |  |                          |                          |
|--|--------------------------|--------------------------|
| Planned Ring Sizes Meet or Exceed Minimums             | <input type="checkbox"/> | <input type="checkbox"/> |
| Adequate Provision for Easy Entrance/Exit from Rings   | <input type="checkbox"/> | <input type="checkbox"/> |
| Telephone (cell phone coverage is acceptable)          | <input type="checkbox"/> | <input type="checkbox"/> |
| Food and/or Other Concessions                          | <input type="checkbox"/> | <input type="checkbox"/> |
| 10 Feet Minimum Aisle Space between Rings              | <input type="checkbox"/> | <input type="checkbox"/> |
| Adequate Viewing Space Ringside for Spectators         | <input type="checkbox"/> | <input type="checkbox"/> |
| Adequate Loading/Unloading Areas                       | <input type="checkbox"/> | <input type="checkbox"/> |
| Adequate Parking for Anticipated Entry                 | <input type="checkbox"/> | <input type="checkbox"/> |
| Handicapped Parking                                    | <input type="checkbox"/> | <input type="checkbox"/> |
| Provision for Overnight Parking                        | <input type="checkbox"/> | <input type="checkbox"/> |
| Provision for Large Vehicles (i.e., motor homes, RV's) | <input type="checkbox"/> | <input type="checkbox"/> |

Parking Areas Clearly Designated

**If Applicable:**

Adequate On-Street Parking

Adequate Off-Street Parking

**If Possible:**

Separate Entrances and Exits

**Sanitation (Human)**

**Acceptable      Unacceptable**

Sufficient Toilet Facilities

**Indoors:**

One Lavatory for Every 100 Persons

One Urinal for Every 200 Males

One Toilet for Every 200 Persons

**Outdoors:**

One Toilet for Every 150 Persons Per Day

Arrangements for Proper Dumping/Emptying

**If Applicable:**

Attendants for Toilet Facilities

**Sanitation (Animal)**

**Acceptable      Unacceptable**

Outdoor Public Exercise Pens (2 per 1,000 dogs, min 48 sq ft each and at least 4' tall)

Indoor Public Exercise Pens (2 per 600 dogs, min 48 sq ft each and at least 4' tall)

Cleaning Supplies (i.e., scoops, sawdust, etc.)

Directional Signs to Exercise Pens

**If Applicable:**

Designated Area for Private Pens

**Grooming**

**Acceptable      Unacceptable**

Adequate Grooming Space for Expected Entry

If Reserved Grooming Offered, There Must Be a Reasonable Amount of Free Grooming of Equal Desirability

If Outdoors, Adequate Tenting for Designated Grooming Areas

**Other (list below):**

**Acceptable**

**Unacceptable**

Any items indicated as "Unacceptable" will be documented in writing by the AKC Executive Field Representative in attendance at the event.

What is the maximum entry per day recommended for this site? \_\_\_\_\_

Comments:

---



---



---



---



---



---



---



---



---



---



# AKC Show/Trial Manual

---

## Appendix C: Reference

<b>Corresponding Date Table</b> _____	<b>13-32</b>
<b>Official AKC Titles for Catalog</b> _____	<b>13-34</b>
<b>Class Divisions</b> _____	<b>13-37</b>
<b>Cluster Site Guidelines</b> _____	<b>13-42</b>
<b>Cluster Site Inspection Guidelines</b> _____	<b>13-43</b>
<b>Judging Ramp Specifications</b> _____	<b>13-47</b>
<b>Training Collars</b> _____	<b>13-48</b>
<b>Site Layouts</b> _____	<b>13-49</b>
All-breed Outdoor Show .....	13-49
All-breed Indoor Show .....	13-50
All-breed Indoor-Outdoor Show .....	13-51
Specialty Indoor-Outdoor Show .....	13-52
Specialty Outdoor Show .....	13-53

# Corresponding Date Table

WEEK	2010 Sat - Sun	2011 Sat - Sun	2012 Sat - Sun	2013 Sat - Sun	2014 Sat - Sun	2015 Sat - Sun	2016 Sat - Sun
1	<b>JAN</b> 9 - 10	<b>JAN</b> 8 - 9	<b>JAN</b> 7 - 8	<b>JAN</b> 5 - 6	<b>JAN</b> 4 - 5	<b>JAN</b> 3 - 4	<b>JAN</b> 9 - 10
2	16 - 17	15 - 16	14 - 15	12 - 13	11 - 12	10 - 11	16 - 17
3	23 - 24	22 - 23	21 - 22	19 - 20	18 - 19	17 - 18	23 - 24
4	30 - 31	29 - 30	28 - 29	26 - 27	25 - 26	24 - 25	30 - 31
5	<b>FEB</b> 6 - 7	<b>FEB</b> 5 - 6	<b>FEB</b> 4 - 5	<b>FEB</b> 2 - 3	<b>FEB</b> 1 - 2	<b>FEB</b> Jan 31 - Feb 1	<b>FEB</b> 6 - 7
6	13 - 14	12 - 13	11 - 12	9 - 10	8 - 9	7 - 8	13 - 14
7	20 - 21	19 - 20	18 - 19	16 - 17	15 - 16	14 - 15	20 - 21
8	27 - 28	26 - 27	25 - 26	23 - 24	22 - 23	21 - 22	27 - 28
9	<b>MAR</b> 6 - 7	<b>MAR</b> 5 - 6	<b>MAR</b> 3 - 4	<b>MAR</b> 2 - 3	<b>MAR</b> 1 - 2	<b>MAR</b> Feb 28 - Mar 1	<b>MAR</b> 5 - 6
10	13 - 14	12 - 13	10 - 11	9 - 10	8 - 9	7 - 8	12 - 13
11	20 - 21	19 - 20	17 - 18	16 - 17	15 - 16	14 - 15	19 - 20
12	27 - 28	26 - 27	24 - 25	23 - 24	22 - 23	21 - 22	26 - 27
13	<b>APR</b> 3 - 4	<b>APR</b> 2 - 3	<b>APR</b> Mar 31 - Apr 1	<b>APR</b> Mar 30 - Mar 31	<b>APR</b> Mar 29 - Mar 30	<b>APR</b> Mar 28 - Mar 29	<b>APR</b> 2 - 3
14	10 - 11	9 - 10	7 - 8	6 - 7	5 - 6	4 - 5	9 - 10
15	17 - 18	16 - 17	14 - 15	13 - 14	12 - 13	11 - 12	16 - 17
16	24 - 25	23 - 24	21 - 22	20 - 21	19 - 20	18 - 19	23 - 24
17	May 1 - May 2	Apr 30 - May 1	28 - 29	27 - 28	26 - 27	25 - 26	Apr 30 - May 1
18	<b>MAY</b> 8 - 9	<b>MAY</b> 7 - 8	<b>MAY</b> 5 - 6	<b>MAY</b> 4 - 5	<b>MAY</b> 3 - 4	<b>MAY</b> 2 - 3	<b>MAY</b> 7 - 8
19	15 - 16	14 - 15	12 - 13	11 - 12	10 - 11	9 - 10	14 - 15
20	22 - 23	21 - 22	19 - 20	18 - 19	17 - 18	16 - 17	21 - 22
21	29 - 30	28 - 29	26 - 27	25 - 26	24 - 25	23 - 24	28 - 29
22	<b>JUN</b> 5 - 6	<b>JUN</b> 4 - 5	<b>JUN</b> 2 - 3	<b>JUN</b> 1 - 2	<b>JUN</b> May 31 - Jun 1	<b>JUN</b> May 30 - May 31	<b>JUN</b> 4 - 5
23	12 - 13	11 - 12	9 - 10	8 - 9	7 - 8	6 - 7	11 - 12
24	19 - 20	18 - 19	16 - 17	15 - 16	14 - 15	13 - 14	18 - 19
25	26 - 27	25 - 26	23 - 24	22 - 23	21 - 22	20 - 21	25 - 26
26	<b>JUL</b> 3 - 4	<b>JUL</b> 2 - 3	<b>JUL</b> Jun 30 - Jul 1	<b>JUL</b> Jun 29 - Jun 30	<b>JUL</b> Jun 28 - Jun 29	<b>JUL</b> Jun 27 - Jun 28	<b>JUL</b> 2 - 3
27	10 - 11	9 - 10	7 - 8	6 - 7	5 - 6	4 - 5	9 - 10
28	17 - 18	16 - 17	14 - 15	13 - 14	12 - 13	11 - 12	16 - 17
29	24 - 25	23 - 24	21 - 22	20 - 21	19 - 20	18 - 19	23 - 24
30	Jul 31 - Aug 1	30 - 31	28 - 29	27 - 28	26 - 27	25 - 26	30 - 31
31	<b>AUG</b> 7 - 8	<b>AUG</b> 6 - 7	<b>AUG</b> 4 - 5	<b>AUG</b> 3 - 4	<b>AUG</b> 2 - 3	<b>AUG</b> 1 - 2	<b>AUG</b> 6 - 7
32	14 - 15	13 - 14	11 - 12	10 - 11	9 - 10	8 - 9	13 - 14
33	21 - 22	20 - 21	18 - 19	17 - 18	16 - 17	15 - 16	20 - 21
34	28 - 29	27 - 28	25 - 26	24 - 25	23 - 24	22 - 23	27 - 28
35	<b>SEP</b> 4 - 5	<b>SEP</b> 3 - 4	<b>SEP</b> 1 - 2	<b>SEP</b> Aug 31 - Sep 1	<b>SEP</b> Aug 30 - Aug 31	<b>SEP</b> Aug 29 - Aug 30	<b>SEP</b> 3 - 4
36	11 - 12	10 - 11	8 - 9	7 - 8	6 - 7	5 - 6	10 - 11
37	18 - 19	17 - 18	15 - 16	14 - 15	13 - 14	12 - 13	17 - 18
38	25 - 26	24 - 25	22 - 23	21 - 22	20 - 21	19 - 20	24 - 25
39	<b>OCT</b> 2 - 3	<b>OCT</b> 1 - 2	<b>OCT</b> Sep 29 - Sep 30	<b>OCT</b> Sep 28 - Sep 29	<b>OCT</b> Sep 27 - Sep 28	<b>OCT</b> Sep 26 - Sep 27	<b>OCT</b> 1 - 2
40	9 - 10	8 - 9	6 - 7	5 - 6	4 - 5	3 - 4	8 - 9
41	16 - 17	15 - 16	13 - 14	12 - 13	11 - 12	10 - 11	15 - 16
42	23 - 24	22 - 23	20 - 21	19 - 20	18 - 19	17 - 18	22 - 23
43	30 - 31	29 - 30	27 - 28	26 - 27	25 - 26	24 - 25	29 - 30
44	<b>NOV</b> 6 - 7	<b>NOV</b> 5 - 6	<b>NOV</b> 3 - 4	<b>NOV</b> 2 - 3	<b>NOV</b> 1 - 2	<b>NOV</b> Oct 31 - Nov 1	<b>NOV</b> 5 - 6
45	13 - 14	12 - 13	10 - 11	9 - 10	8 - 9	7 - 8	12 - 13
46	20 - 21	19 - 20	17 - 18	16 - 17	15 - 16	14 - 15	19 - 20
47	27 - 28	26 - 27	24 - 25	23 - 24	22 - 23	21 - 22	26 - 27
48	<b>DEC</b> 4 - 5	<b>DEC</b> 3 - 4	<b>DEC</b> 1 - 2	<b>DEC</b> Nov 30 - Dec 1	<b>DEC</b> Nov 29 - Nov 30	<b>DEC</b> Nov 28 - Nov 29	<b>DEC</b> 3 - 4
49	11 - 12	10 - 11	8 - 9	7 - 8	6 - 7	5 - 6	10 - 11
50	18 - 19	17 - 18	15 - 16	14 - 15	13 - 14	12 - 13	17 - 18
51	25 - 26	24 - 25	22 - 23	21 - 22	20 - 21	19 - 20	24 - 25
52	Jan 1 - Jan 2	Dec 31 - Jan 1	29 - 30	28 - 29	27 - 28	26 - 27	Dec 31 - Jan 1

WEEK	2017 Sat - Sun	2018 Sat - Sun	2019 Sat - Sun	2020 Sat - Sun	2021 Sat - Sun	2022 Sat - Sun	2023 Sat - Sun
1	JAN 7 - 8	JAN 6 - 7	JAN 5 - 6	JAN 4 - 5	JAN 10 - 11	JAN 8 - 9	JAN 7 - 8
2	14 - 15	13 - 14	12 - 13	11 - 12	17 - 18	15 - 16	14 - 15
3	21 - 22	20 - 21	19 - 20	18 - 19	24 - 25	22 - 23	21 - 22
4	28 - 29	27 - 28	26 - 27	25 - 26	Jan 31 - Feb 1	29 - 30	28 - 29
5	FEB 4 - 5	FEB 3 - 4	FEB 2 - 3	FEB 1 - 2	FEB 7 - 8	FEB 5 - 6	FEB 4 - 5
6	11 - 12	10 - 11	9 - 10	8 - 9	14 - 15	12 - 13	11 - 12
7	18 - 19	17 - 18	16 - 17	15 - 16	21 - 22	19 - 20	18 - 19
8	25 - 26	24 - 25	23 - 24	22 - 23	Feb 28 - Mar 1	26 - 27	25 - 26
9	MAR 4 - 5	MAR 3 - 4	MAR 2 - 3	MAR Feb 29 - Mar 1	MAR 7 - 8	MAR 5 - 6	MAR 4 - 5
10	11 - 12	10 - 21	9 - 10	7 - 8	14 - 15	12 - 13	11 - 12
11	18 - 19	17 - 18	16 - 17	14 - 15	21 - 22	19 - 20	18 - 19
12	25 - 26	24 - 25	23 - 24	21 - 22	28 - 29	26 - 27	25 - 26
13	APR 1 - 2	APR Mar 31 - Apr 1	APR Mar 30 - Mar 31	APR Mar 28 - Mar 29	APR 4 - 5	APR 2 - 3	APR 1 - 2
14	8 - 9	7 - 8	6 - 7	4 - 5	11 - 12	9 - 10	8 - 9
15	15 - 16	14 - 15	13 - 14	11 - 12	18 - 19	16 - 17	15 - 16
16	22 - 23	21 - 22	20 - 21	18 - 19	25 - 26	23 - 24	22 - 23
17	29 - 30	28 - 29	27 - 28	25 - 26	May 2 - May 3	Apr 30 - May 1	29 - 30
18	MAY 6 - 7	MAY 5 - 6	MAY 4 - 5	MAY 2 - 3	MAY 9 - 10	MAY 7 - 8	MAY 6 - 7
19	13 - 14	12 - 13	11 - 12	9 - 10	16 - 17	14 - 15	13 - 14
20	20 - 21	19 - 20	18 - 19	16 - 17	23 - 24	21 - 22	20 - 21
21	27 - 28	26 - 27	25 - 26	23 - 24	30 - 31	28 - 29	27 - 28
22	JUN 3 - 4	JUN 2 - 3	JUN 1 - 2	JUN May 30 - May 31	JUN 6 - 7	JUN 4 - 5	JUN 3 - 4
23	10 - 11	9 - 10	8 - 9	6 - 7	13 - 14	11 - 12	10 - 11
24	17 - 18	16 - 17	15 - 16	13 - 14	20 - 21	18 - 19	17 - 18
25	24 - 25	23 - 24	22 - 23	20 - 21	27 - 28	25 - 26	24 - 25
26	JUL 1 - 2	JUL Jun 30 - Jul 1	JUL Jun 29 - Jun 30	JUL Jun 27 - Jun 28	JUL 4 - 5	JUL 2 - 3	JUL 1 - 2
27	8 - 9	7 - 8	6 - 7	4 - 5	11 - 12	9 - 10	8 - 9
28	15 - 16	14 - 15	13 - 14	11 - 12	18 - 19	16 - 17	15 - 16
29	22 - 23	21 - 22	20 - 21	18 - 19	25 - 26	23 - 24	22 - 23
30	29 - 30	28 - 29	27 - 28	25 - 26	Aug 1 - Aug 2	30 - 31	29 - 30
31	AUG 5 - 6	AUG 4 - 5	AUG 3 - 4	AUG 1 - 2	AUG 8 - 9	AUG 6 - 7	AUG 5 - 6
32	12 - 13	11 - 12	10 - 11	8 - 9	15 - 16	13 - 14	12 - 13
33	19 - 20	18 - 19	17 - 18	15 - 16	22 - 23	20 - 21	19 - 20
34	26 - 27	25 - 26	24 - 25	22 - 23	29 - 30	27 - 28	26 - 27
35	SEP 2 - 3	SEP 1 - 2	SEP Aug 31 - Sep 1	SEP Aug 29 - Aug 30	SEP 5 - 6	SEP 3 - 4	SEP 2 - 3
36	9 - 10	8 - 9	7 - 8	5 - 6	12 - 13	10 - 11	9 - 10
37	16 - 17	15 - 16	14 - 15	12 - 13	19 - 20	17 - 18	16 - 17
38	23 - 24	22 - 23	21 - 22	19 - 20	26 - 27	24 - 25	23 - 24
39	OCT Sep 30 - Oct 1	OCT Sep 29 - Sep 30	OCT Sep 28 - Sep 29	OCT Sept 26 - Sept 27	OCT 3 - 4	OCT 1 - 2	OCT Sept 30 - Oct 1
40	7 - 8	6 - 7	5 - 6	3 - 4	10 - 11	8 - 9	7 - 8
41	14 - 15	13 - 14	12 - 13	10 - 11	17 - 18	15 - 16	14 - 15
42	21 - 22	20 - 21	19 - 20	17 - 18	24 - 25	22 - 23	21 - 22
43	28 - 29	27 - 28	26 - 27	24 - 25	Oct 31 - Nov 1	29 - 30	28 - 29
44	NOV 4 - 5	NOV 3 - 4	NOV 2 - 3	NOV Oct 31 - Nov 1	NOV 7 - 8	NOV 5 - 6	NOV 4 - 5
45	11 - 12	10 - 11	9 - 10	7 - 8	14 - 15	12 - 13	11 - 12
46	18 - 19	17 - 18	16 - 17	14 - 15	21 - 22	19 - 20	18 - 19
47	25 - 26	24 - 25	23 - 24	21 - 22	28 - 29	26 - 27	25 - 26
48	DEC 2 - 3	DEC 1 - 2	DEC Nov 30 - Dec 1	DEC Nov 28 - Nov 29	DEC 5 - 6	DEC 3 - 4	DEC 2 - 3
49	9 - 10	8 - 9	7 - 8	5 - 6	12 - 13	10 - 11	9 - 10
50	16 - 17	15 - 16	14 - 15	12 - 13	19 - 20	17 - 18	16 - 17
51	23 - 24	22 - 23	21 - 22	19 - 20	26 - 27	24 - 25	23 - 24
52	30 - 31	29 - 30	28 - 29	26 - 27	Jan 2 - Jan 3	Dec 31 - Jan 1	30 - 31

---

# Official AKC Titles for Catalog

## Breed, Obedience, Agility, Field Trial, Herding, Lure Coursing and Coonhound Titles

A complete list of title can be found at <http://www.akc.org/events/titles.cfm>.

AFC	Amateur Field Champion
AJP	Excellent Agility Jumper Preferred
AX	Agility Excellent
AXJ	Excellent Agility Jumper
AXP	Agility Excellent Preferred
BN	Beginner Novice
CA	Coursing Ability
CAA	Coursing Ability Advanced
CAX	Coursing Ability Excellent
CAX2	Coursing Ability Excellent 2
CCH	Coonhound Champion
CD	Companion Dog
CDX	Companion Dog Excellent
CFC	Field Champion
CGC	Canine Good Citizen
CGCA	AKC Community Canine
CGCH	Grand Champion (Coonhound)
CGF	Grand Field Champion
CGN	Grand Nite Champion
CGW	Grand Water Race Champion
CH	Champion
CM	Certificate of Merit
CNC	Nite Champion
CSG	Supreme Grand Champion
CSGF	Supreme Grand Field Champion
CSGN	Supreme Grand Nite Champion
CSGW	Supreme Grand Water Race Champion
CT	Champion Tracker
CWC	Water Race Champion
CWSG	World Show Champion Grand Champion
DC	Dual Champion
EE	Endurance Earthdog
FC	Field Champion
FTC	Agility FAST Century
FTCP	Agility FAST Century 1 Preferred
GCH	Grand Champion (Conformation)
GDSC	Gun Dog Stake Champion
GN	Graduate Novice
GO	Graduate Open
HC	Herding Champion
HI	Herding Intermediate
HIAdsc	Herding Intermediate Course A (ducks, sheep, cattle)
HIBdsc	Herding Intermediate Course B (ducks, sheep, cattle)
HICs	Herding Intermediate Course C (sheep)
HS	Herding Started
HSAdsc	Herding Started Course A (ducks, sheep, cattle)
HSBdsc	Herding Started Course B (ducks, sheep, cattle)
HSCs	Herding Started Course C (sheep)



HT	Herding Tested
HX	Herding Excellent
HXAdsc	Herding Excellent Course A (ducks, sheep, cattle)
HXBdsc	Herding Excellent Course B (ducks, sheep, cattle)
HXCc	Herding Excellent Course C (sheep)
JC	Junior Courser
JE	Junior Earthdog
JH	Junior Hunter
JHA	Junior Hunter Advanced
JHR	Junior Hunter Retriever
JHU	Junior Hunter Upland
LCX	Lure Courser Excellent
MACH	Master Agility Champion
MC	Master Courser
ME	Master Earthdog
MFB	Master Bronze FAST
MFC	Master Century FAST
MFG	Master Gold FAST
MFP	Agility Master FAST Excellent Preferred
MFPB	Master Bronze FAST Preferred
MFPC	Master Century FAST Preferred
MFPG	Master Gold FAST Preferred
MFPS	Master Silver FAST Preferred
MFS	Master Silver FAST
MH	Master Hunter
MHA	Master Hunter Advanced
MHR	Master Hunter Retriever
MHU	Master Under Upland
MJB	Master Bronze Jumpers With Weaves
MJC	Master Century Jumpers With Weaves
MJG	Master Gold Jumpers With Weaves
MJP	Master Excellent Jumper Preferred
MJPB	Master Bronze Jumpers With Weaves Preferred
MJPC	Master Century Jumpers With Weaves Preferred
MJPG	Master Gold Jumpers With Weaves Preferred
MJPS	Master Silver Jumpers With Weaves Preferred
MJS	Master Silver Jumpers With Weaves
MNH	Master National Hunter
MX	Master Agility Excellent
MXB	Master Bronze Agility
MAC	Master Century Agility
MXF	Agility Master FAST Excellent
MXG	Master Gold Agility
MXJ	Master Excellent Jumper
MXP	Master Agility Excellent Preferred
MXPB	Master Bronze Agility Preferred
MXPC	Master Century Agility Preferred
MXPG	Master Gold Agility Preferred
MXPS	Master Silver Agility Preferred
PXS	Master Silver Agility
NA	Novice Agility
NAC	National Agility Champion
NAFC	National Amateur Field Champion
NAGDC	National Amateur Gundog Champion
NAJ	Novice Agility Jumper
NAP	Novice Agility Preferred
NF	Agility FAST Novice
NFC	National Field Champion

NFP	Agility FAST Novice Preferred
NGDC	National Gundog Champion
NJP	Novice Agility Jumper Preferred
NOC	National Obedience Champion
NOGDC	National Open Gun Dog Champion
OA	Open Agility
OAJ	Open Agility Jumper
OAP	Open Agility Preferred
OF	Agility FAST Open
OFF	Agility FAST Open Preferred
OGM	Obedience Grand Master
OJP	Open Agility Jumper Preferred
OM	Obedience Master
OTCH	Obedience Trial Champion
PACH	Preferred Agility Champion
PAX	Preferred Agility Excellent
PCD	Pre-Companion Dog
PCDX	Pre-Companion Dog Excellent
PNAC	Preferred National Agility Champion
PT	Pre-Trial Tested
PUTD	Pre-Utility Dog
RA	Rally Advanced
RAE	Rally Advanced Excellent
RE	Rally Excellent
RGDSC	Retrieving Gun Dog Stake Champion
RN	Rally Novice
RNC	AKC Rally National Champion
SC	Senior Courser
SE	Senior Earthdog
SH	Senior Hunter
SHA	Senior Hunter Advanced
SHR	Senior Hunter Retriever
SHU	Senior Hunter Upland
T2B	Time 2 Beat
T2BP	Time 2 Beat Preferred
TC	Triple Champion
TD	Tracking Dog
TDU	Tracking Dog Urban
TDX	Tracking Dog Excellent
THD	Therapy Dog Title
TQX	Triple Q Excellent
TQXP	Triple Q Excellent Preferred
UD	Utility Dog
UDX	Utility Dog Excellent
VCCH	Versatile Companion Champion – OTCH, MACH or PACH, and CT
VCD1	Versatile Companion Dog 1 - CD, NA, NAJ, TD or CD, NAP, NJP, TD
VCD2	Versatile Companion Dog 2 - CDX, OA, OAJ, TD or CDX, OAP, OJP, TD
VCD3	Versatile Companion Dog 3 - UD, AX, AXJ, TDX or UD, AXP, AJP, TDX
VCD4	Versatile Companion Dog 4 – UDX, MX, MXJ, VST or UDX, MXP, MJP, VST
VER	Versatility
VST	Variable Surface Tracker
WNC	World Nite Champion
XF	Agility FAST Excellent
XFP	Agility FAST Excellent Preferred

---

# Class Divisions

## Breed Varieties

Trophies and/or prizes for the following should be listed in premium lists under all varieties. In all-breed premium lists, the varieties *MAY NOT* have BEST OF BREED competition. In premium lists for independent specialty events, the events *MUST* have ribbons offered for BEST OF VARIETY and BEST OF BREED.

Cocker Spaniels	Black (to include Black and Tan), ASCOB, Parti-color
Beagles	13" and under, over 13" not exceeding 15"
Dachshunds	Longhaired, Wirehaired, Smooth
Bull Terriers	White, Colored
Manchester Terriers	Standard, Toy
Chihuahuas	Smooth Coat, Long Coat
English Toy Spaniels	King Charles and Ruby, Blenheim and Prince Charles
Poodles	Toy, Miniature, Standard
Collies	Rough, Smooth

## Breeds in which color may be a condition of a division of a class

Labrador Retrievers	Black, Yellow, Chocolate
English Cocker Spaniels	Solid Color, to include Any Solid Color, except White, with Tan Points; Parti-Color, including Roans and Ticked

**The English Cocker Spaniel Club of America, and those designated specialty clubs *ONLY*, may divide the Open Class by the above colors.**

Basenjis	Red & White; Black & White; Black, Tan & White; Brindle & White
Dachshunds	(All Three Varieties): Miniature – 11 lbs & under @ 12 months old or over.  This class may also be divided by Red; and Black and Tan; and Any Other Allowed Color

**(The Dachshund Club of America *ONLY*, may divide the Open Miniature Class by the above colors.)**

Boxers	Brindle, Fawn
Bullmastiff	Brindle, Any Other Allowed Color
Doberman Pinschers	Black, Any Other Allowed Color
Giant Schnauzers	Black; Pepper and Salt (Open Classes Only)
Great Dane	Brindle, Fawn, Blue, Black, Harlequin, Mantle
Newfoundlands	Black, Other than Black
Miniature Schnauzers	Salt and Pepper, Black and Silver, Black
Cavalier King Charles Spaniels	Black and Tan, Blenheim, Tri-color, Ruby
Japanese Chin	Black & White, Red & White, Black & White with Tan Points

Shiba Inu	Red/Red Sesame or Black and tan/AOAC
Miniature Pinschers	Black and Rust-Red, Chocolate and Rust and Red

**Open Classes at Local and National Specialties or at “Supported Entry” all-breed shows.**

**6-9 and 9-12 month puppy classes at Nationals *ONLY*.**

Pekingese	Parti-color, Black and Tan, Black, White and Cream (Off White, not Blond or Fawn);
<b>At Specialty Shows ONLY</b>	Parti-color, Black and Tan, Black, White and Cream (Off White, not Blond or Fawn); Any Other Allowed Color
Pomeranians	Red, Orange, Cream and Sable; Black, Brown and Blue; Any Other Allowed Color, Pattern or Variation
Pugs	Black, Fawn
Chow Chows	Black, Red, Any Other Color
Dalmatians	Black Spotted, Liver Spotted
French Bulldogs	Brindle, Cream and Fawn, Pied and White
Australian Shepherds	Blue Merle, Black, Red Merle, Red All with or without White Markings and/or Tan Points
Border Collies	Black and White, Any Other Allowed Color
Collies	Sable and White, Tri-color, Blue Merle, White
Briards	Tawny, Black and Gray

**Open classes at National, Regional, and Supported Specialties may be divided by the above colors.**

Shetland Sheepdogs	Sable & White, AOAC; <u>or</u> , Sable & White, Black (Tri, Bi-Black), Blue (Blue Merle, Bi-Blue)
--------------------	---

**Breeds and Varieties in which weight may be a condition of division of a class**

Dachshunds	(All Three Varieties): Miniature – 11 lbs. & under & @ 12 months old or over.
Manchester Terriers (Standard)	Open Classes -- over 12 lbs., not exceeding 16 lbs.; over 16 lbs., not exceeding 22 lbs.
Manchester Terriers (Toy)	Open Classes -- 7 lbs. and under; over 7 lbs. And not exceeding 12 lbs.  Weight is a variety definition and becomes part of the conditions of every class.

Pekingese

**At All-breed Shows**

Open, dogs, under 8 lbs., if 12 months old or over

Open, dogs, 8 lbs. and over (and under 8 lbs. if less than 12 months old)

**At Specialty Shows  
(or All-breed if  
warranted by  
previous year's  
entry)**

Open, dogs, under 6 lbs., if 12 months old or over

Open, dogs, 6 lbs. and under 8 lbs., if 12 months old or over.

Open, dogs, 8 lbs. and over (and under 8 lbs. if less than 12 months old)

Boston Terriers

Division of Open classes for dogs under 15 lbs., 15 lbs. And under 20 lbs., 20 lbs. And over and not to exceed 25 lbs.

(Also under 15 lbs. And 15 lbs. And over) BBE classes at Specialty Shows.

**The following breeds may have classes divided at dog shows based on breed characteristics other than weight, height or color**

Ibizan Hound Smooth coat, Wire coat

Portuguese Podengo Pequeno Smooth coat, Wire coat

St. Bernards Longhaired, Shorthaired

Skye Terriers Drop ears, Prick ears

Brussels Griffons Rough coat, Smooth coat

Chinese Cresteds Hairless, Powderpuff

Papillons Erect ear, Drop ear

Chinese Shar-Pei Brush coat, Horse coat

Chow Chows Rough coat, Smooth coat

Pyrenean Shepherd Smooth-faced, Rough-faced (Open Class Only)

**Breeds and varieties in which height may be a condition of division of a class**

American Eskimo Dogs Open Class (Toy) 9-12 inches

Open Class (Miniature) over 12 inches-15 inches

Open Class (Standard) over 15 inches-19 inches

Xoloitzcuintli Open Class (Toy) 10-14 inches

Open Class (Miniature) over 14 inches-18 inches

Open Class (Standard) over 18 inches-23 inches

## Breeds Which May be judged on a Table

A complete list can be found at [http://images.akc.org/pdf/judges/table\\_breeds.pdf](http://images.akc.org/pdf/judges/table_breeds.pdf).

### Sporting

Boykin Spaniel (Optional)	Cocker Spaniel	English Cocker Spaniel
---------------------------	----------------	------------------------

### Hound

Basenji	Beagle	Dachshund
Petit Basset Griffon Vendéen	Portuguese Podengo Pequeno	Whippet (Optional)

### Terrier

Australian Terrier	Bedlington Terrier	Border Terrier
Cairn Terrier	Cesky Terrier	Dandie Dinmont Terrier
Fox Terrier (Smooth)	Fox Terrier (Wire)	Glen of Imaal Terrier
Lakeland Terrier	Manchester Terrier (Standard)	Miniature Bull Terrier (optional)
Miniature Schnauzer	Norfolk Terrier	Norwich Terrier
Parson Russell Terrier	Rat Terrier	Russell Terrier
Scottish Terrier	Sealyham Terrier	Skye Terrier
Welsh Terrier	West Highland White Terrier	

### Toy

Affenpinscher	Brussels Griffon	Cavalier King Charles Spaniel
Chihuahua	Chinese Crested	English Toy Spaniel
Havanese	Italian Greyhound	Japanese Chin
Maltese	Manchester Terrier (Toy)	Miniature Pinscher
Papillon	Pekingese	Pomeranian
Poodle (Toy)	Pug	Shih Tzu
Silky Terrier	Toy Fox Terrier	Yorkshire Terrier

### Non-Sporting

American Eskimo Dog	Bichon Frise	Boston Terrier
Coton de Tulear	French Bulldog	Lhasa Apso
Löwchen	Norwegian Lundehund	Poodle (Miniature)
Schipperke	Shiba Inu	Tibetan Spaniel
Tibetan Terrier	Xoloitzcuintli (Toy & Miniature)	

### Herding

Cardigan Welsh Corgi	Pembroke Welsh Corgi	Puli
Pyrenean Shepherd	Shetland Sheepdog	Swedish Vallhund

## **FSS/Miscellaneous Class**

Miniature American Shepherd	Peruvian Inca Orchid (Small & Medium)	Pumi
-----------------------------	---------------------------------------	------

## **Breeds which may be judged on a ramp**

Boykin Spaniel (Optional)	Clumber Spaniels	Field Spaniel
Sussex Spaniels	Welsh Springer Spaniel	*Basset Hounds*
Whippets (optional)	Irish Terrier	Kerry Blue Terriers
Soft Coated Wheaten Terrier	Staffordshire Bull Terriers	*Bulldogs*
Chinese Shar-Pei	Chow Chows	Keeshonden
Norwegian Buhund	Polish Lowland Sheepdog	

\*By Board approved policy, are expected to be judged on the ramp during breed, Group, and BIS.

## **Breeds eligible to compete in the Miscellaneous Class**

These breeds may also compete in Obedience, Tracking, Agility and Junior Showmanship at events held on or after September 1, 2001<sup>1</sup>

A list of breeds that are included in the Miscellaneous Classes can be procured from the AKC website at [http://www.akc.org/breeds/miscellaneous\\_class.cfm](http://www.akc.org/breeds/miscellaneous_class.cfm)

---

<sup>1</sup> AKC Board Policy, June 2001

---

## Cluster Site Guidelines

Each club is responsible for the conduct of its own event.

Each club will have one representative on the Cluster Committee.

Work out event schedule at least one year in advance. Any date conflicts must be resolved by the clubs.

Submit all event applications together in one package to Event Operations, if possible. This will prevent unnecessary delay in issuing all event approvals. This applies to applications for “regular” shows, not designated specialties.

Judges selection, contracts, etc. are the responsibility of the individual show-giving clubs and any disputes must be worked out by the clubs.

[Common Site Application](#)<sup>2</sup> form may be submitted in lieu of individual host club letters. All club representatives must sign the form.

Club representatives will work with Executive Field Representatives, Grounds Chair/Committee and Superintendent on daily site inspections for their respective events.

Cluster Committee may remain the same from year to year.

### **Cluster committee is also responsible for the following:**

Securing accessory services and equipment such as telephones, public address system, potable water, chairs and tables, all concessions.

Submitting a consolidated Disaster and Emergency Plan form to Event Operations. The form should identify all clubs in the cluster and their event dates. The form may be signed for the cluster committee by a designated individual. Each club in a cluster must have their own Emergency Response Coordinator, who is also a member of the club.

Dealing with outside personnel such as site management.

Making sure there is adequate insurance coverage for all clubs/days.

Each club is responsible for identifying itself on its event application as part of a cluster.

The Common Site Application must accompany the event application for each participating club.

---

<sup>2</sup> Form may be downloaded from the AKC web site



---

# Cluster Site Inspection Guidelines

The following guidelines are provided for clusters consisting of 4 or more clubs. The AKC Executive Field Representative, working in conjunction with the Grounds Committee, will objectively monitor the site and facilities to ensure that the safety, health and well-being of the dogs, exhibitors, judges, spectators is considered at those conformation/obedience events held as part of a multi-show cluster.

## Indoor, Outdoor and Combination Sites

### Club & Superintendent responsible for

Preparation of grounds, event site layout

Set up and dismantle event equipment

### Club responsible for

Advising local authorities of event, layout, exact location and time

### Executive Field Representative, Club & Superintendent responsible for

Evaluating site on a daily basis to ensure cleanliness and that resources (exercise pens, toilets, water, parking, etc.) are not overtaxed

## Selecting and Utilizing the Site

- Within Host Club's geographic area or located equidistant from all clubs
- Accommodates the entry
- Adequate access
- Grounds in good condition
- Adequate sanitary facilities
- Parking arrangements
- Food concessions

## The Event Site

- Proper lighting
- Adequate ventilation (indoor)
- Adequate heating or air conditioning (indoor)
- Layout drawn up
- Adequate unloading facilities
- Adequate parking for anticipated entry
- Entrances and exits
- CPR-certified EMT on grounds all days
- Access to medical services for dogs and people
- Adequate protection (outdoor)
- Condition of grounds (outdoor)
- Restroom facilities (portable or existing)

- Water, electricity, phone service (outdoor)
- Provision for site clean-up

### **Event Operations / Records**

- Include directions
- Submit event layout
- Check out any new prospective event site(s)

### **Clubs using a Superintendent**

- Ring dividers
- Exercise pens, scoopers, sawdust, chips, etc.
- Mats
- Tents
- Set-up, clean-up crew(s), crate handlers
- Clubs should provide the Superintendent with all information and material by the contract deadline
- Site layout
- Access to site prior to the event
- Other -- specified in contract
- Club should make provisions for equipment, supplies and personnel not provided by Superintendent

### **Setting Up the Site**

#### **Rings, Equipment**

- Obedience/Rally rings in accordance with Regulations
- Breed rings approximately in accordance with suggestions
- A minimum of 10 feet of aisle space between rings
- Adequate viewing space for spectators at ringside
- Provide non-slip surface (indoors), level rings with short grass (outdoors)
- Maintenance of grounds and equipment before, during and after event hours
- Arrange access to the grounds for personnel, vendors or suppliers before event hours
- Securing and transporting equipment for the event
- Securing telephones or access to telephones
- PA system
- Securing water supply
- Clean-up

#### **Tenting, if outdoor site**

- Adequate protection from elements; minimum of 10 x 20 suggested in every ring

- Adequate tenting for expected entry
- Adequate cover for judge in ring

## Safety

- Oversee that local rules and ordinances are followed
- Secure emergency personnel
- Secure veterinarian or services

## Parking

- Planning, supervision and staffing of all parking and unloading areas
- Layout of parking, including handicapped and motor homes; coordinate with Grounds Chairman
- Arrange for towing services
- Parking and traffic control personnel
- Parking for the handicapped
- Adequate loading and unloading areas
- Provision for large vehicles, motor homes, trailers, etc.
- Parking areas clearly designated
- Regulations for on-street parking
- Coordinate with local officials
- Separate entrances and exits (if possible)
- Provision for emergency towing
- Crate handlers at unloading area

## Sanitation Requirements

- Sufficient toilet facilities: a minimum of one toilet for every 150 persons for a one day event (outdoors)
- Adequate signs and directions to toilet facilities
- Compliance with National Plumbing Code
- Handicapped facilities

## Sanitation (Animal)

The AKC Board of Directors has approved the following revision to the Show/Trial Manual to more adequately address exercise area requirements at Dog Shows. The following change to the Show/Trial Manual becomes effective April 1, 2007:

### All-Breed shows must provide the following:

- **Gated exercise pens of sturdy construction with a minimum size of 6' X 8' X 4' (48 sq. ft. for each pen).**
- **For shows with suitable outdoors exercise areas and clean-up supplies the following number of ex-pens must be provided based on the number of entries:**
  - **0 – 1,000 dogs – 2 ex-pens**

- 1,001 – 2,000 dogs – 4 ex-pens
- 2,001 – 3,000 dogs – 6 ex-pens
- 3,001 – 4,000 dogs – 8 ex-pens
- **For shows without suitable outdoors exercise areas the following number of ex-pens must be provided based on the number of entries:**
  - 0 – 600 dogs – 2 ex-
  - 601 – 1,200 dogs – 4 ex- pens pens
  - 1,201 – 1,800 dogs – 6 ex-pens
  - 1,801 – 2,400 dogs – 8 ex-pens
  - 2,401 – 3,000 dogs – 10 ex-pens
  - 3,001 – 3,600 dogs – 12 ex-pens
  - 3,601 – 4,200 dogs – 14 ex-pens

**In all cases, a minimum of two ex-pens must be available. In the event of inclement weather at least two ex-pens must be under cover.**

**Individual sites may require deviation of this requirement. The inspecting AKC Field Staff will approve deviations on a site-by-site basis.**

**Specialty shows must have a minimum of two exercise pens suitable to the size of the breed.**

Any questions regarding these requirements should be directed to AKC Event Operations, (919) 816-3579 or [eventplans@akc.org](mailto:eventplans@akc.org).

Designated area for private exercise pens

---

## Judging Ramp Specifications

If your club uses a licensed superintendent for its events, appropriate ramps are included with their standard equipment. To assist those clubs that do not use the services of a licensed superintendent, the AKC has established general guidelines for construction of a judging ramp.

**Construction** Any stable material may be used including the use of folding legs.

**Surface** ..... Rubber-matted

**Length** ..... 4 feet

**Width** ..... 2 feet

**Height** ..... 15 - 24 inches

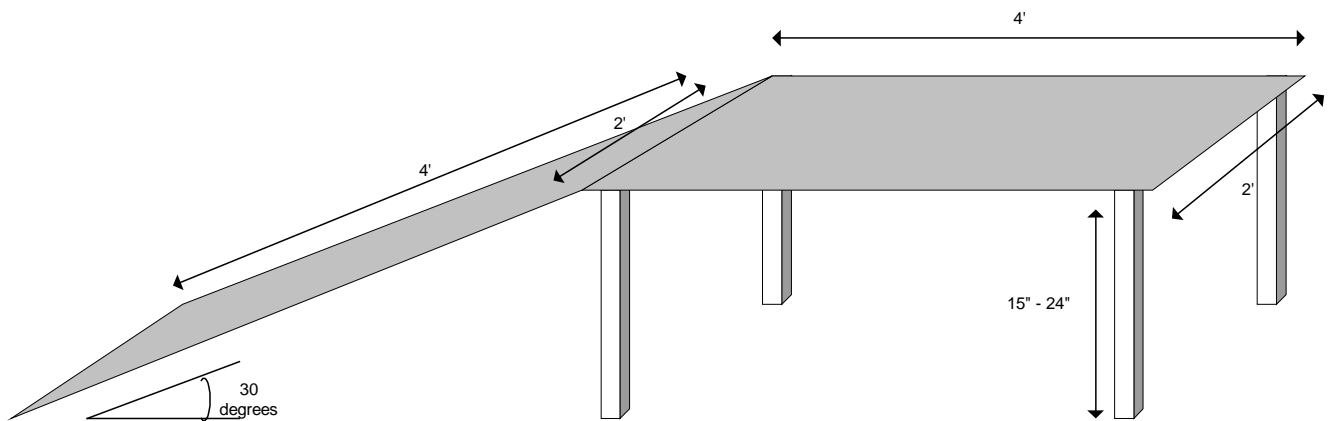

---

## Training Collars

Special training devices that are used to control and train dogs, including but not limited to, collars with prongs, electronic collars used with transmitters, muzzles and head collars may not be used on dogs at AKC events, except as allowed in the AKC Rules, Regulations, and policies.

Although they can be useful in the training of a dog, there is a point at which owners should have sufficient control of their dogs to manage them on regular neck collars, without the use of special training collars. This is the point at which dogs are acceptable on the grounds of AKC competitive events and will have the opportunity to participate in those events.<sup>3</sup>

---

<sup>3</sup> AKC Board Policy, July 2001

# Site Layouts

## All-breed Outdoor Show

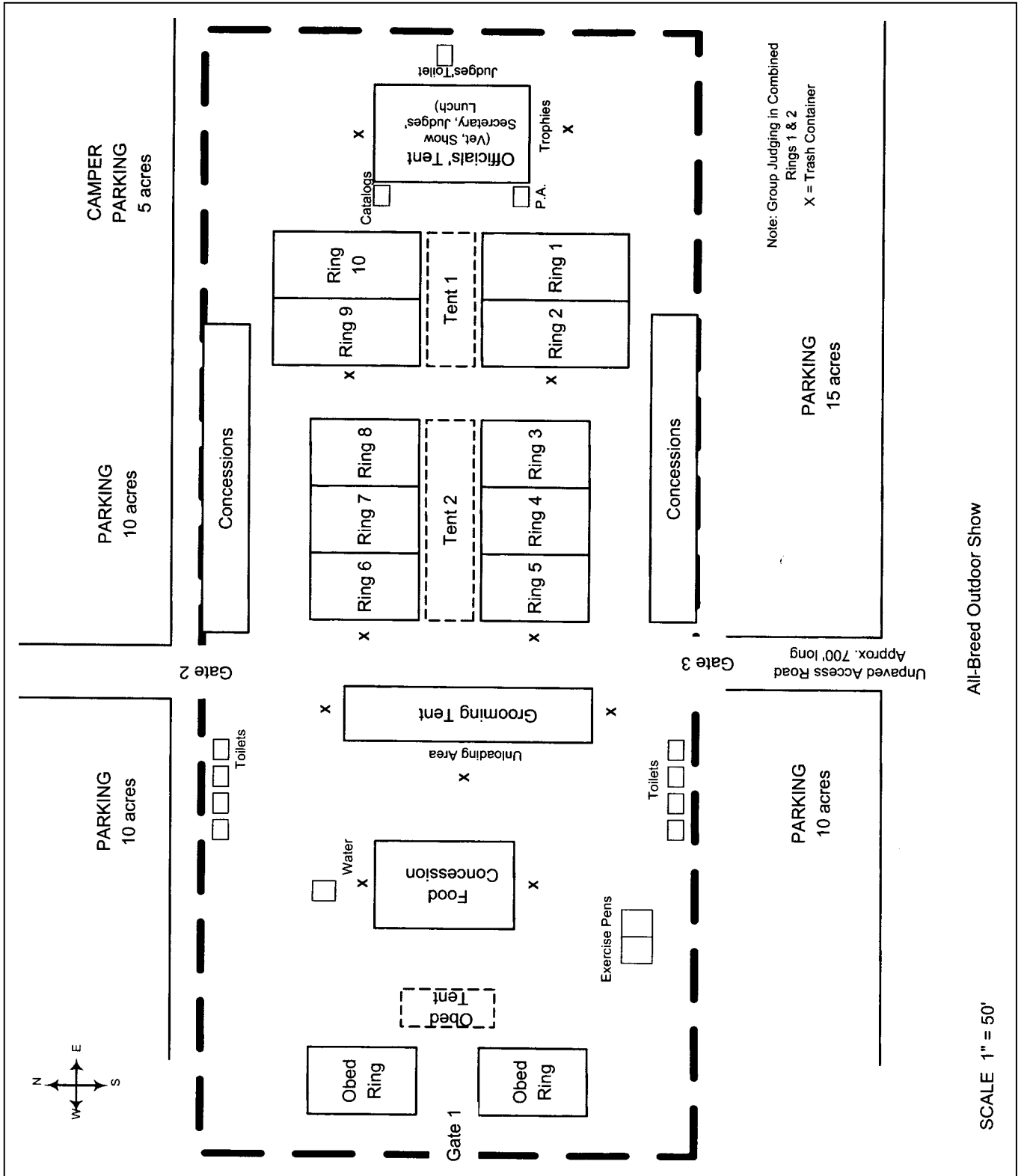





# All-breed Indoor-Outdoor Show

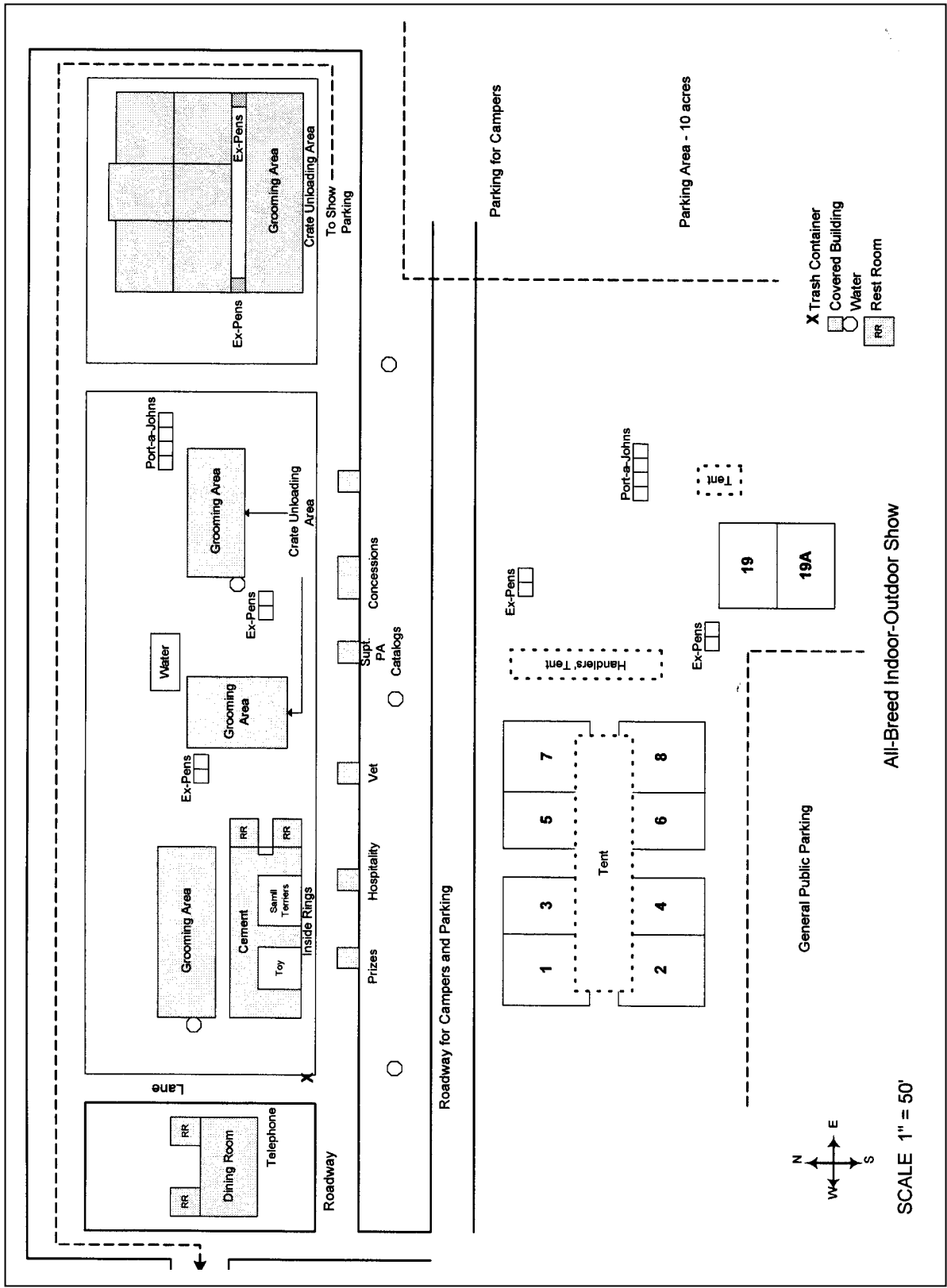



# Specialty Outdoor Show

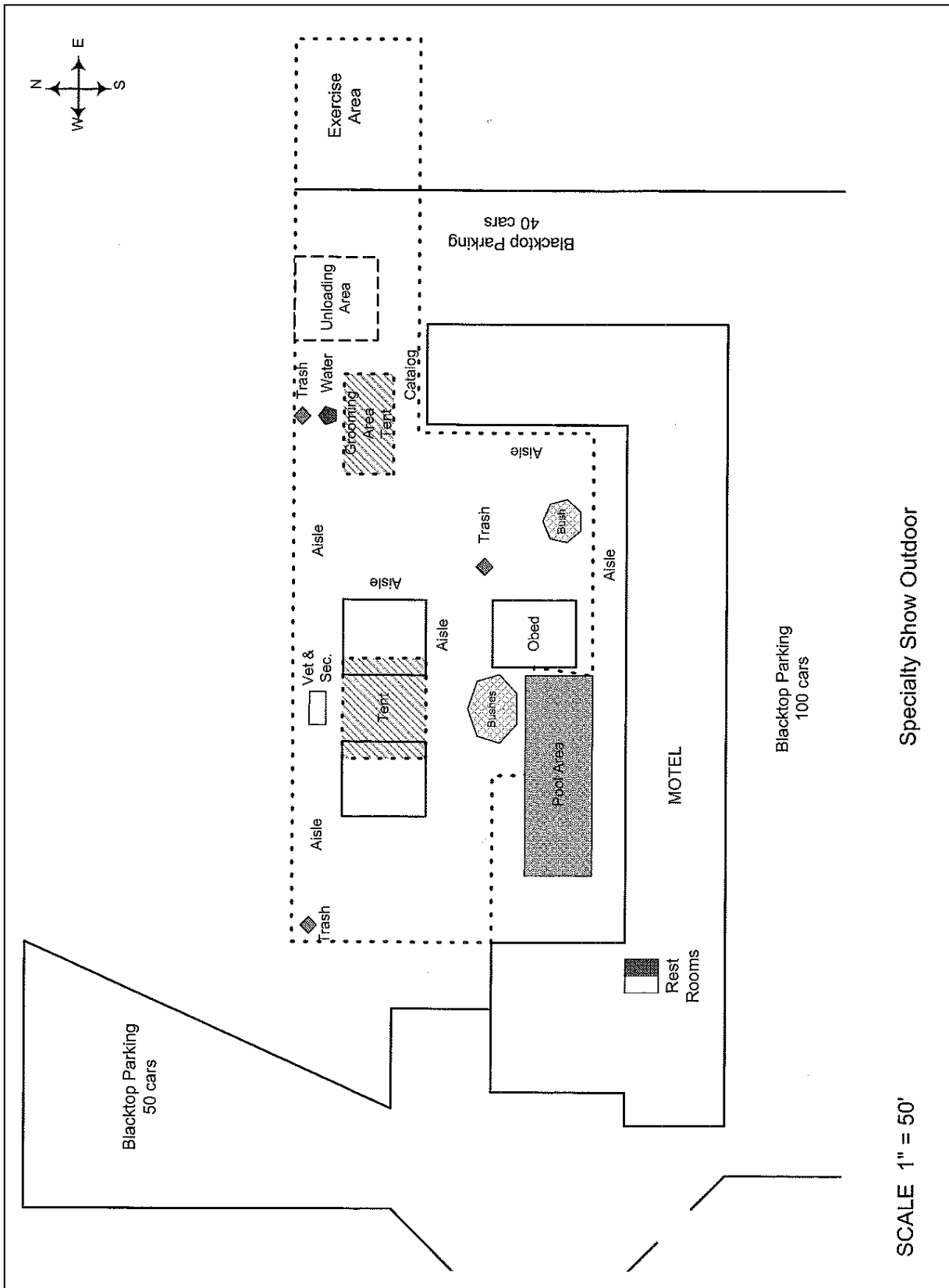



# AKC Show/Trial Manual

---

## Appendix D: Example Correspondence and Forms

Event Financial Planning Sheet _____	13-55
Host Club (Permissions) Letter _____	13-56
Judging Availability Inquiry Letter _____	13-57
Judging Confirmation Letter _____	13-58
Judge's Contract _____	13-59
Hospitality: Judges Information Sheet _____	13-60
Dog Show Photography Agreement _____	13-61
Letter for Radio Coverage _____	13-62
Press Release for Print Media _____	13-63
Dogs in Unventilated Vehicles _____	13-64
Crate Identification Labels _____	13-67

---

# Event Financial Planning Sheet

## Revenue

### Pre-Event

- Catalog advertising
- Trophy fund
- Concession space fees
- Entry fees

### Day-of-Event Income

- Parking fees
- Admission fees
- Catalog sales
- Food sales
- Other

## Expenses

### Event Site

- Site rental
- Site preparation
- Tenting
- Hired personnel
- Site clean-up
- Portable lavatories
- Other (signs, ring equipment, etc.)

### Event Preparation

- Superintendent/Show Secretary
  - Premium list printing and mailing
  - Judging program printing and mailing
  - Acknowledgment mailing
  - Catalog printing
  - Ribbons, rosettes and badges
- Judges
- Trophies
- Club hospitality (pre-show and/or after-show dinner, breakfast, luncheon)
- EMT
- Stewards
- Insurance
- Veterinary expenses
- Advertising
- Contingency plans
- Emergency and Disaster Plan

### Event Committee

- Mail
- Telephone
- Clerical

---

# Host Club (Permission) Letter

## YOUR CLUB'S LETTERHEAD

### Return Address

On behalf of the ***name of Kennel Club***, the following clubs are given permission to hold the indicated event in conjunction with our event beginning ***date of event*** through the date indicated.

<b>Club Name</b>	<b>Event Type (Designated, Concurrent, Evening, or Sweepstakes)</b>	<b>Through End of Month Year</b>
<i>Raleigh Dachshund Club</i>	<i>Designated with sweepstakes</i>	<i>July 2020</i>
<i>Halifax Shiba Inu Club</i>	<i>Concurrent</i>	<i>January 2017</i>

Yours truly,

***Signature***

***Name***

***Title***

***Phone/fax/Email***

Please keep a copy for your club records.

---

# Judging Availability Inquiry Letter

## YOUR CLUB'S LETTERHEAD

### Return Address

Dear **Judge's name**,

On behalf of the **name of Kennel Club**, I am inquiring as to your availability to judge the following assignment at our show to be held on **day, date** at **location (name of facility and address)**. This is an **indoor/outdoor** facility.

**List all breeds, obedience/rally trial classes, Junior Showmanship, groups, Best in Show, etc. to be assigned**

Please return this letter to me by **date** to confirm your availability. If you are not available for one or more of your published breeds or classes, please list those in the space provided.

---

Include all specific financial arrangements required (fee or rate per dog plus all anticipated expenses). I look forward to hearing from you by **date**. A timely reply from our club will follow. Thank you for your consideration.

Fee \_\_\_\_\_

Other \_\_\_\_\_

Yours truly,

**Signature**

**Name**

**Title**

**Phone/fax/Email**

---

### Letter should include the following:

- Complete name, address and phone/fax number of person corresponding with the judge.
- Name of the club and type of show, date and location (indoor/outdoor), including city and state.
- A complete listing of the proposed assignment including any special attractions that may be offered and required to judge.
- Notice that the show will be videotaped or televised, if applicable.
- A request for financial information the judge requires, fees or rate per dog, travel and all other anticipated expenses.
- Include a date that the judge must respond by.

---

# Judging Confirmation Letter

YOUR CLUB'S LETTERHEAD

Return Address

*Date of letter*

**NAME**

**ADDRESS**

**CITY, STATE ZIP CODE**

Dear **Judge's name**:

This is to confirm your availability to judge at our All-breed Show and Obedience Trial on **date/month/year**, which is an **indoor/outdoor** event. Please take a moment to review the enclosed contract, sign it and return one copy to me. The **Your Kennel Club** looks forward to your judging at our annual show.

You will receive a Judges Information Sheet from our Hospitality Chair at a later date. Please contact me if I may be of assistance in making plans for your assignment.

Sincerely,

**Your Name**

**Your Position in Club**

**Address**

**City, state zip code**

**Phone**

**Fax**

**Email**



---

# Judge's Contract

## YOUR CLUB'S LETTERHEAD

### Return Address

I agree to judge for the ***name of kennel club*** on \_\_\_\_\_, 20\_\_\_\_.

Our club will pay ***fee or rate per dog***, plus agreed upon expenses.

\$\_\_\_\_\_ Fee          \$\_\_\_\_\_ Per Dog, plus estimated expenses.

OR

\_\_\_\_\_ Expenses only

TOTAL ESTIMATED COST TO CLUB:          \$\_\_\_\_\_

The expenses consists of: ***List all agreed upon expenses such as: coach air fare, Club designated hotel (one night unless approved for additional night by Show Chair), food, ground transportation, etc. Incidentals will be the responsibility of the judge.***

THE ASSIGNMENT I AM ACCEPTING IS: **List entire assignment you are giving to the judge**

\_\_\_\_\_

\_\_\_\_\_

Breed(s) that I will not be able to judge:

\_\_\_\_\_

Special Request: \_\_\_\_\_

SIGNED: \_\_\_\_\_

DATE: \_\_\_\_\_, 20 \_\_\_\_\_

**(Send TWO copies to the Judge, requesting the Judge to sign one and return it to the Show Chair.)**

---

# Hospitality: Judges Information Sheet

Name of Show (club provides this) Date of Show (club provides this)

Judge's Name (club provides this)

Phone \_\_\_\_\_ Fax \_\_\_\_\_ Mobile \_\_\_\_\_

Email \_\_\_\_\_

Emergency Contact \_\_\_\_\_ Phone \_\_\_\_\_

## Accommodations Needed (please check)

Single  Double

Room needed evening prior to show  Room needed evening following show

Smoking  Non-Smoking

## Airport Pickup (Arrival)

Yes  No

Airline \_\_\_\_\_ Flight Number \_\_\_\_\_ Arrival Time \_\_\_\_\_

## Transportation Needed to Airport (Departure)

Yes  No

Airline \_\_\_\_\_ Flight Number \_\_\_\_\_ Departure Time \_\_\_\_\_

## Judges' Dinner

Date (club provides this) Time (club provides this)

Location (club provides this) Attire (club provides this)

Will Attend  Will Not Attend Number of Guests \_\_\_\_\_

Names of Guests \_\_\_\_\_

Special Dietary Needs, Judge \_\_\_\_\_

Special Dietary Needs, Guest \_\_\_\_\_

## Judge's Signature \_\_\_\_\_

### Please mail or fax this sheet to the person listed below:

Club Contact: (club provides this)

Address: (club provides this)

(club provides this)

Phone: (club provides this)

Fax (club provides this)

---

# Dog Show Photography Agreement

Agreement between \_\_\_\_\_

Name of Photographer

and \_\_\_\_\_

Name of Club holding event

*(Name of Photographer)* shall be engaged as the Official Photographer for the *(Name of Kennel Club)* on *(Date of Show)* under the following conditions:

1. The event-giving club agrees to list the above-named photographer as the Official Photographer in the Premium List and Catalog.
2. Photographs shall be made on request, shall be of good technical quality and portray the exhibit to the best advantage that circumstances permit.
3. Photographs shall be a standard size (i.e., 8 x 10). At least one copy will be sent to the Exhibitor for their decision to purchase. Color, Black and white and a full range of other sizes and services will be available to the Exhibitor on special request.
4. Show management assures the Official Photographer of the exclusive privilege of making photographs for sale to the Exhibitors and shall permit no other Photographer to do so. This clause does not affect newspaper and television photographers on specific assignment and/or amateur photographers making pictures for their personal use.
5. The Official Photographer shall supply the sponsoring club with the following photographs free of charge:
  - Two 8 x 10 color photographs of Best in Show and of each Group First, plus any other picture needs of the club.
6. Other provisions (specify below):

\_\_\_\_\_  
\_\_\_\_\_

SIGNED:

For the club by:

For the photographer by:

\_\_\_\_\_  
Name/Date

\_\_\_\_\_  
Name/Date

\_\_\_\_\_  
Address

\_\_\_\_\_  
Address

\_\_\_\_\_  
Phone/Fax/Email

\_\_\_\_\_  
Phone/Fax/Email

---

# Letter for Radio Coverage

## YOUR CLUB'S LETTERHEAD

### Return Address

The ***name of kennel club***, a non-profit organization, will be holding its annual all-breed dog show on ***date***. Will you please air the attached announcement as often as possible between now and ***event date***. Thank you for your consideration.

“The ***name of kennel club*** will hold its ***xxth*** (e.g., *60th*) annual all-breed dog show and obedience trial ***day, date*** at ***location (include street)***. This is an American Kennel Club approved event. At shows, dogs are judged against their individual breed's standards. Each winner is awarded from one to five points based on the number of entries in its respective breed. These points advance a dog towards its Champion title. Over the course of the day, the entrants are narrowed down to a single dog - Best in Show. Additionally, many breeds will be represented in the Obedience competitions, where they are judged on their training: their ability to heel on and off lead, stand for an examination, come when called, sit and lie down on command, and, at the higher test levels, jumping, retrieving and obeying non-verbal commands. In the Junior Showmanship competition, children aged 9 -18 will exhibit their own dogs as they compete for prizes by displaying their skills in handling dogs.

Admission for adults is \$\_\_\_\_\_, children under \_\_\_\_\_ (e.g., 12) \$\_\_\_\_\_ (or free). There are concessions featuring many dog and pet-related items, such as food, toys, books and magazines, as well as vendors offering a variety of breakfast and lunch items for you and your family.

There are ***xxxx*** (e.g., *2,500*) dogs entered representing ***xxx*** (e.g., *140*) different AKC-recognized breeds. The show starts at ***time*** and runs throughout the day. Group and Best in Show should start at ***time***. Come join us in a good time for the entire family. For more information call ***phone number***.”

Sincerely,

***Name***

***Title***

***Address***

---

# Press Release for Print Media

## YOUR CLUB'S LETTERHEAD

### Return Address

The ***name of kennel club***, a non-profit organization, will be holding its annual all-breed dog show on ***date***. Will you please print the attached announcement as often as possible between now and ***show date***. Thank you for your consideration.

"The ***name of kennel club*** will hold its ***xxth*** (e.g., *60th*) annual all-breed dog show and obedience trial ***day, date*** at ***location (include street)***. This is an American Kennel Club approved event.

There are ***xxxx*** (e.g., *2,500*) dogs entered representing ***xxx*** (e.g., *140*) different AKC-recognized breeds. The show starts at ***time*** and runs throughout the day. Over the course of the day, each breed will be judged in the conformation ring as dogs compete for awards and titles. Additionally, many breeds will be represented in the Obedience competition and demonstrate their ability in obeying their owners' commands. In the Junior Showmanship ring children aged 9 -18 will exhibit their own dogs as they compete for prizes by displaying their skills in handling dogs.

Admission for adults is \$\_\_\_\_\_, and children under 12 are \$\_\_\_\_\_ (or free). There will be many concessions featuring dog foods, all types of supplies, photography, canine antiques, book and magazines. The entire family will have a good time. For more information call ***phone number.***"

Sincerely,

***Name***

***Title***

***Address***

---

INCLUDE AN EYE-CATCHING BLACK & WHITE 8 X 10 PHOTO WITH THE PRESS RELEASE

---

# Dogs in Unventilated Vehicles

## MEMORANDUM

**To:** All Clubs  
**From:** Show Events - Linda More and Barbara Schwartz  
**Date:** July 9, 1999

We are all concerned about the dangers posed to dogs confined in vehicles at dog events, especially at this time of year. In May 1997, the Events Committee of AKC's Board of Directors approved a notice of "Waiver of Rights" which you may include in your premium list to help give your club the ability to rescue dogs from improperly ventilated vehicles. This Waiver has been effectively used by a number of clubs. You may also post the Waiver on your show grounds, and/or place it on flyers to hand out to those entering the show grounds.

Suggested wording is:

*All persons attending this dog show/trial hereby waive any claim for damages against (club name) or its members, in the event a motor vehicle must be entered to rescue a dog from overheating or suffocation due to improper ventilation.*

**We suggest you check relevant state laws regarding the effectiveness of such a waiver. Many states have laws supporting potential action.**

Enclosed is a master copy of a poster which you may reproduce for your club's use. The second enclosure is a copy of a flyer to be given to participants and spectators to place on the dashboard of their cars if dogs are to be left in the vehicles.

We wish to remind you that Section V, page 6 of the Dealing with Misconduct booklet states:

"When a dog is seriously injured or dies in connection with an event, the Event Committee must conduct a Preliminary Investigation to determine if negligence or willful conduct of an individual caused the injury or death."

This section also requires a written report.

Increased education, publicity, and vigilance can prevent tragedies from occurring at dog events, and we hope the above information and the enclosures will be helpful to your club.

# If I'm in distress.....



**Please go to the  
Club Officials  
and  
page my owner**



AMERICAN  
KENNEL CLUB™

(Owner's Name...Please Print )

[www.akc.org](http://www.akc.org)

GDFLY2 (4/06)

# WARNING:



## LEAVING YOUR DOG IN A HOT CAR MAY BE HAZARDOUS TO ITS HEALTH.

When it's 80 degrees outside, a car can heat up to over **120 degrees** in just minutes. In a temperature that high, a dog could easily die. That's why the American Kennel Club® recommends that dog owners **never** leave their dog alone in a car during the warm weather.

For additional tips on canine summer care, write: AKC®,  
8051 Arco Corporate Drive, Suite 100, Raleigh, NC 27617  
and request a free copy of AKC Canine Summer Safety Guidelines.



AMERICAN  
KENNEL CLUB™



---

# Crate Identification Labels

## MEMORANDUM

**To:** All AKC Show-Giving Clubs

**Subject:** Crate Identification Labels

The welfare and safety of dogs is a critical issue at all events. Using crate identification labels is a recommended way of identifying who is responsible for each dog at shows.

Participation in the use of crate labels is encouraged. Crate labels may be purchased from any local office supply store.

Labels should include: Breed of Dog, Dog's Call Name, Owner's Name, Contact Phone Number or Responsible Party at the Show, and any Special Conditions, medical or otherwise.

The need for notification of owners is sometimes necessary, and critical time can be lost if this information is not readily available.



In case of emergency, find someone to help me!!!

My name is \_\_\_\_\_

My owner is \_\_\_\_\_

Phone number \_\_\_\_\_

Person responsible  
at the show \_\_\_\_\_

Special conditions \_\_\_\_\_



# AKC Show/Trial Manual

---

## Appendix E: **Sample** **Show Documents**

**Judges Books** \_\_\_\_\_ **13-70**



NAME OF KENNEL CLUB (EVENT#)  
BREED or VARIETY

DAY, MONTH DATE, YEAR  
JUDGE

(CLASS) Catalog#	DOGS Award	(CLASS) Catalog#	DOGS Award	(CLASS) Catalog#	DOGS Award	(CLASS) Catalog#	DOGS Award	(CLASS) Catalog#	DOGS Award

WINNERS WITHHELD

RESERVE WITHHELD

PLEASE ENTER CATALOG NUMBER IF AWARDED

I certify that in my opinion, the **WINNER** and **RESERVE** are deserving of Championship points on this day.

WINNER \_\_\_\_\_

RESERVE \_\_\_\_\_

(CLASS) Catalog#	BITCHES Award	(CLASS) Catalog#	(SEX) Award	(CLASS) Catalog#	(SEX) Award	(CLASS) Catalog#	(SEX) Award	(CLASS) Catalog#	(SEX) Award

WINNERS WITHHELD

RESERVE WITHHELD

PLEASE ENTER CATALOG NUMBER IF AWARDED

I certify that in my opinion, the **WINNER** and **RESERVE** are deserving of Championship points on this day.

WINNER \_\_\_\_\_

RESERVE \_\_\_\_\_

**BEST OF BREED COMPETITION:**

**CHECK BOX IF AWARDING GRAND CHAMPION POINTS  
TO BEST OF BREED OR BEST OF OPPOSITE SEX**

BEST OF BREED

BEST OF WINNERS \_\_\_\_\_

BEST OF OPPOSITE SEX

SELECT DOG \_\_\_\_\_

SELECT BITCH \_\_\_\_\_



# AKC Show/Trial Manual

## 14: Index

### A

Admission Ticket	
judges.....	2-22
mailing.....	2-22, 9-5, 9-8, 13-17
media, complimentary.....	2-19
price.....	9-5, 13-15
printing.....	11-7
stewards.....	2-12, 9-5
Advertising	
billing.....	2-17
catalog.....	2-16, 2-17
contract.....	2-16
deadlines.....	2-16
flyers.....	2-20
posters.....	2-20
printer.....	2-17, 13-16
proofreading.....	13-15
revenue.....	2-17
soliciting.....	13-15
Alternate site.....	3-2
AKC Policy	
aisle width.....	4-5
banners and signs.....	10-11
event cancellation.....	3-3
judging assignments.....	6-4
judging conflict.....	6-5
Registered Handlers catalog listing.....	9-9
tenting.....	4-6
wickets.....	10-10
AKC Publications	
AKC Gazette.....	6-3, 13-14
brochures.....	2-20, 4-2
Judges Directory.....	6-3, 6-7, 13-14
ordering.....	10-12
required at event.....	2-9, 10-12, 13-18
videos.....	2-24
AKC Registered Handlers Program	
catalog listing.....	9-9
Americans with Disabilities Compliance Checklist..	2-13, 13-25

Application.....	See Event Application
Assistant Show Chair.....	2-10
Award of Merit for Superior Quality.....	8-11

### B

Badges.....	See Ribbons
Banners	
advertising.....	2-20
Banners and Signs, AKC	
Grounds/Equipment Chair.....	2-14
superintendent.....	10-12, 11-7
Bill Payment.....	2-23
Billing	
advertisers.....	2-17
obedience cluster.....	13-20
trophy donations.....	2-18
Booth	
AKC Educational.....	2-24
education.....	2-24
health services.....	8-10
Budget	
club financial records.....	3-2
contingencies.....	3-2
cost of judges.....	6-6
publicity.....	2-19
review.....	2-24
trophies.....	2-18

### C

Cancellation	
alternate site.....	3-2
AKC policy.....	3-3
entry.....	11-5
event.....	3-3
event site.....	3-2
judge.....	7-5
premium list notice.....	9-3
weather conditions.....	3-3
Cash Pick-Up	
schedule.....	2-23
Show Chair.....	2-9

Catalog .....	9-8	Contracts and Agreements	
advertisers .....	2-16, 2-17	catalog advertisers .....	2-16
advertising .....	2-16, 13-16	copies .....	3-3
AKC Registered Handlers listing .....	9-9	event site .....	2-8, 13-14
AKC Titles.....	9-9, 13-34	judges .....	5-3, 6-2, 6-6, 6-7, 6-8, 13-59
area for sales.....	2-17, 4-7	judge's travel.....	6-8
club business.....	2-17	local club territory .....	10-4
combined.....	9-9	other clubs .....	6-6, 13-42
delivery .....	13-17	package .....	11-8
designated specialty.....	8-4	photographer .....	2-8, 2-25, 13-14, 13-16, 13-61
event number .....	9-2	premium list .....	9-2
judges .....	2-17	records.....	2-5, 6-8
local specialty club hosting.....	8-3	specialty club .....	6-2
marked.....	9-9, 11-5, 13-19	superintendent 2-8, 11-2, 11-6, 11-8, 13-14, 13-15	
members.....	2-17	supported entry.....	8-4
multi-day event .....	9-8	tenting .....	4-6
OFA,CERF numbers .....	9-9	trophy offerings and pledges .....	2-18
official photographer .....	13-61	vendors.....	2-16
pre-event sales.....	9-8	veterinarian .....	13-15
price .....	13-15	Correspondence	
printing.....	11-7	change of judging assignment.....	7-3, 7-5
required information .....	9-9, 9-10	contacting the accused.....	12-3
sales .....	2-17, 9-8, 9-9	event number.....	9-2
special awards.....	8-11	information sheet for selected judges.....	6-8
stewards .....	2-12, 2-17	judge's availability.....	6-7
supported entry .....	8-4	judges travel confirmation.....	2-22
Cellular phones .....	2-21	judging assignment confirmation.....	6-7, 6-8
Clean-Up		media follow-up .....	2-19
crew .....	13-16, 13-44	records.....	2-5
event site .....	2-13, 4-9, 13-28, 13-44	supported entry outside territory.....	8-5
exercise pens .....	2-13, 4-9, 13-45	Corresponding Date .....	10-3
obedience rings .....	4-5	Table.....	13-32
rings.....	13-44	<b>D</b>	
supervision .....	2-14	Deadlines	
supplies .....	11-7	advertising .....	2-16
tools .....	2-14, 4-9	Application for Show/Trial.....	10-2
Cluster .....	10-7	Disaster and Emergency Plan .....	10-2
approval.....	10-7	event records .....	10-9, 11-5
catalog sales.....	9-8	Hearing Committee report .....	13-26
club liaison.....	2-8	judges panel .....	6-2, 10-2, 13-14
combined catalog .....	9-9	judging program mailing .....	9-5, 10-2
combined premium list .....	9-2	newspaper .....	2-20
committee.....	10-7, 10-8, 13-42	Officer/Membership List.....	10-2
expense sharing .....	3-2, 10-8	premium list mailing.....	10-2
host club .....	10-7	printer.....	2-17, 11-7
required paperwork .....	10-7	Report of Dog Show or Obedience Trial .....	10-3
site checklist .....	13-28	Show Chair .....	2-7
site guidelines.....	13-42	special attraction.....	10-2
Committee Chair .....	2-10	Statement of Compliance .....	10-2
Committee, Event.....	See Event Committee	superintendent's material .....	13-44
Committee, Hearing .....	See Hearing Committee	Trophy Chair .....	2-17
Committee, Judges Selection .....	See Judges Selection Committee	Directions	
Common Site Application.....	5-2, 10-8, 13-42	emergency facilities .....	2-21
Companion Event		judges' information.....	2-22, 6-7
budgeting expenses .....	3-2	judging program.....	9-7
liaison .....	2-8	motels .....	9-5

to event site.....	6-7, 9-7, 11-8, 13-44	site layout .....	10-8
to toilet facilities.....	13-45	supported entry .....	8-4
veterinary emergency clinic.....	2-21	sweepstakes.....	8-6
Disability Compliance Checklist		Event Checklist.....	13-14
Grounds/Equipment Chair.....	2-13	committee chairs .....	2-10
Parking Chair .....	2-14	Event Committee	
Disaster and Emergency Plan .....	2-7	authority.....	2-4, 2-5
consolidated.....	10-8, 13-42	chairs.....	2-8
Grounds/Equipment Chair.....	2-12	continuity .....	2-3
Obedience Chair .....	2-11	criteria.....	2-5
on-line event management.....	10-3	dogs disqualified by.....	2-4
required at event .....	2-21	exhibiting at event .....	2-6
Safety Chair .....	2-20, 13-42	exhibiting restrictions.....	2-7
Show Chair.....	2-7, 2-9	management and production .....	2-3
written procedures.....	2-20	minimum number.....	2-5
Dog show tours .....	2-24	minutes.....	2-5
Donations		novice members .....	2-3
billing .....	2-18	organization chart.....	2-6
distribution .....	2-24	scales .....	10-10
parking proceeds.....	2-15	secretary.....	2-8
soliciting.....	13-15	size .....	2-5
trophies.....	2-17	structure.....	2-3, 2-6
<b>E</b>		volunteers .....	2-5
Education Credit		wickets.....	10-10
dog show tours.....	2-24	Event Entry	
multiple events requirement.....	10-6	cancellation .....	11-5
provisional judges .....	6-3	changing and correction .....	11-4
Emergency Personnel.....	13-17, 13-43, 13-45	closing date .....	13-17
Emergency Plan.. See Disaster and Emergency Plan		estimation .....	6-5
Emergency Vehicles		fax.....	11-3
ambulance.....	2-14	fees.....	9-3
location .....	2-21	limitation .....	9-3
Parking Chair .....	2-14	multiple-dog.....	8-8, 8-9
traffic flow .....	2-14, 4-7	online .....	11-3
Equipment		receiving .....	11-3, 11-8
chairs.....	2-13, 11-7, 13-16, 13-17, 13-42	single-dog .....	8-8
club responsibility .....	13-44	telephone.....	11-3
cluster committee .....	13-42	transferring .....	11-4
dismantle .....	2-11, 2-13, 13-43	Event number .....	9-2
inventory.....	13-19	Event Records	
judging ramp .....	13-47	Committee Secretary.....	2-5
maintenance.....	2-13	deadline .....	10-9, 11-5, 13-19
obedience.....	2-11, 4-5, 11-7	Executive Field Representative recommendations .....	4-4
setting up.....	2-13, 13-44	financial .....	3-2
storage .....	2-13	financial report.....	2-24
superintendent contract.....	11-6	hearing report .....	12-4
videotaping.....	10-15	history file .....	2-5
Event Application		judges books .....	10-9, 13-19, 13-21
cluster.....	10-7, 13-42	judges' contracts.....	6-7
deadline.....	10-2, 13-14	judge's dates and assignments.....	6-7
designated specialty.....	8-4	judge's hospitality information .....	6-8
evening specialty.....	8-5	marked catalog.....	9-9, 10-9, 11-6, 13-19
local club permission.....	10-5	minutes.....	2-5
online event management.....	10-3	parent club consent.....	8-8
parent club consent.....	8-4	procedures and deadlines .....	11-5
Show Chair.....	2-8	trophy income report .....	2-18



trophy inventory report .....	2-18	multiple-dog entry .....	8-8
Event Site		parking .....	2-15, 4-9
alternate .....	3-2	recording .....	9-3, 10-3, 10-9, 11-5, 13-19
clean-up .....	2-14, 4-9, 13-28, 13-44	service .....	9-3, 11-5, 13-19
concurrent specialty .....	8-6	stewards organization .....	13-11
contract .....	2-8	sweepstakes, futurities .....	8-6
diagram .....	4-2, 9-8	veteran sweepstakes .....	8-7
electricity .....	4-4, 13-44	Filming .....	See Videotaping
evening specialty .....	8-5	Food Concessions .....	2-15, 4-4, 13-42, 13-43
layout .....	4-2, 11-8, 13-14, 13-43, 13-44, 13-49	judges' lunch break .....	7-4
lease .....	2-8	site inspection .....	13-28
legal requirements .....	2-8	Forms	
liaison .....	2-8	Application for Show/Trial .....	10-2, 13-20
limits .....	10-8	Common Site Application .....	5-2, 10-8, 13-42
not previously used .....	10-8	Disaster and Emergency Plan .....	2-9, 2-20, 10-2, 13-42
notice .....	10-5	judge's expense sheet .....	2-23
permits .....	2-8	Judges Panel .....	10-2, 13-20
rates .....	4-2	master entry .....	11-3
restrictions .....	11-8	official AKC entry .....	8-8, 11-2
suitability .....	10-8	Procedural Checklist .....	12-3, 13-26
taxes .....	2-8	Report of Dog Show or Obedience Trial .....	10-3, 11-5, 12-4, 13-19
telephones .....	4-4, 13-17	Special Attractions Form .....	8-10, 10-2
Executive Field Representative		Statement of Compliance .....	10-2
attendance .....	2-24	suppliers .....	10-9
entry limits .....	10-8	<b>G</b>	
event recommendations .....	4-4	Generators .....	2-16, 4-4, 4-9, 9-5
event site .....	4-4	Golf Carts .....	2-13
notice of misconduct charges .....	12-2	Grooming	
site approval .....	4-2	indoor .....	4-3
site evaluation .....	4-2, 10-9, 13-19, 13-28, 13-43	outdoor .....	4-5
site inspection .....	2-24, 10-7, 13-42	reserve space .....	4-10
Exercise Pens		tenting .....	4-6
clean-up .....	2-13, 4-9	Grounds	
conditions .....	4-10	access .....	2-13
limitations .....	2-13, 4-10	chair .....	2-12
minimum number .....	4-10, 13-29, 13-45	preparation .....	13-17
private .....	13-46	<b>H</b>	
premium list .....	9-4	Hearing Committee	
superintendent .....	11-7	minimum number .....	12-2
Exhibiting Restrictions		Hospitality	
event committee .....	2-6	judges' information .....	6-8, 13-60
judging program .....	9-7	media .....	2-20
photographer .....	2-7, 2-25	Host Club	
sweepstakes or futurity judge .....	8-6	cluster .....	10-7, 13-20
veterinarian .....	2-21	letter .....	13-42, 13-56
Expenses		multiple event approval .....	10-6
contingency .....	3-2	revenue sharing .....	2-17
expenditure approval .....	2-23	Hotel	
judges .....	6-6, 13-20	exhibitor .....	2-22
judge's estimate .....	6-6	judges .....	2-22
<b>F</b>		rates .....	2-22
Fee			
concession space .....	2-16, 13-15		
designated specialty .....	8-4		
entry .....	3-3, 8-7, 8-8, 11-2, 11-3		
judges .....	6-7, 13-20, 13-59, 13-57		

<b>I</b>		
Insurance .....	3-3, 13-8, 13-42	
rain .....	13-16	
<b>J</b>		
Judge's Bag		
stewards .....	2-12	
trophies .....	2-19	
Judges		
assignment confirmation .....	6-7	
assignment division .....	6-5	
assignment limitation .....	6-4	
availability .....	6-7, 7-6, 13-57	
Best in Show judge .....	7-4	
Best Puppy in Show .....	8-10	
change of assignment .....	7-3, 7-5	
checks .....	2-23	
confirmation .....	6-8, 13-58	
conflicts .....	6-5, 6-8, 13-15	
contract .....	6-7	
directory .....	6-3	
expense sheet .....	2-23	
group .....	7-4	
hardship cases .....	6-6	
information sheet .....	6-8	
judging rate .....	6-6	
lodging .....	2-22, 6-7, 13-15	
luncheon .....	2-23	
meals .....	2-22, 6-7	
notice of change .....	7-8	
notice of withdrawal .....	7-5	
overload .....	7-6	
permit .....	6-2, 13-14	
Puppy Group .....	8-10	
responsibility .....	6-8	
special attractions .....	8-10	
submitting .....	6-2	
substitute .....	7-6, 11-5	
transportation .....	2-23	
travel .....	6-4, 6-8, 13-59	
Veteran Group .....	8-10	
videotaping notice .....	6-7	
videotaping requirement .....	10-12	
visiting .....	6-3, 13-17	
Judges Books		
errors .....	11-6	
suppliers .....	10-9	
Judges Panel		
event budget .....	6-6	
on-line event management .....	10-3	
Show Chair .....	2-8	
Judges Selection Committee .....	6-2	
Judge's Table .....	2-13	
Judging Program		
campgrounds .....	2-14	
change of judge .....	7-5, 9-6, 11-5	
composite, obedience cluster .....	13-20	
directions to event site .....	9-7, 11-8	
exhibitor limits .....	9-7	
judge change .....	7-5, 7-8, 9-6, 11-5	
mailing deadline .....	9-5, 10-2	
official starting time .....	7-2	
overnight parking .....	9-8	
parking proceeds .....	2-15	
posted closing time .....	7-2	
printing .....	11-7	
private exercise pens .....	4-10	
recommended information .....	9-7	
required information .....	9-5	
rest areas .....	2-15	
site diagram .....	9-8	
site layout .....	4-8, 9-8	
special attraction .....	9-7	
stewards .....	2-12, 9-5	
Veteran group judging .....	8-10	
Judging Ramp .....	See Ramp, Judging	
Junior Showmanship class .....	8-3	
transfer .....	11-4	
<b>L</b>		
Loading/Unloading		
crate placement .....	4-7, 13-45	
event site facilities .....	13-28, 13-43	
Grounds/Equipment Chair .....	2-14	
handicapped .....	13-24	
Parking Chair .....	2-14	
site inspection .....	13-28	
site set-up .....	13-43	
supervision .....	4-9, 13-43	
traffic flow .....	4-7	
windshield stickers .....	9-8	
Local Authorities		
advertising posters, permission .....	2-20	
emergency personnel and vehicles .....	2-20	
event information .....	13-43	
local ordinances .....	2-20, 4-7, 13-45	
notification of event .....	13-16	
parking regulations .....	4-8	
Lodging		
judges .....	2-22, 6-7, 13-15	
judges' information .....	2-22, 6-8	
judging program .....	9-7	
premium list .....	9-5	
quality .....	2-22	
special rates .....	2-22	
Lunch Tickets		
distribution .....	13-18	
Executive Field Representative .....	2-23	
judges .....	2-23	
printing .....	11-7	
stewards .....	2-12, 13-18	
superintendent .....	2-23	

<b>M</b>		
Mats.....	10-11	
Map		
local area, judges' information.....	2-22	
site layout .....	2-13, 9-5	
to event site .....	9-7	
to veterinarian's office.....	9-7	
vendor space.....	2-15	
Media		
AKC requirements .....	10-12	
judges .....	10-12	
judge's availability letter .....	13-59	
notice to Event Operations .....	10-2	
notice to judges .....	6-7	
radio coverage.....	13-62	
press announcements.....	2-19, 13-63	
publicity, television stations .....	2-19	
video/televising.....	9-4	
Miscellaneous class .....	8-2	
premium list .....	9-4	
Motorized Vehicles.....	13-22	
<b>N</b>		
National Owner-Handled Series (NOHS).....	5-4, 8-11	
Neutered Dogs		
brood bitch class .....	8-9	
stud dog class .....	8-9	
veterans sweepstakes.....	8-7	
Nonregular classes.....	8-7	
adding.....	5-4	
multiple dog .....	8-8, 8-9	
removing.....	5-4	
single dog .....	8-8	
<b>O</b>		
Obedience		
chair .....	2-10	
cluster.....	13-20	
divided classes .....	7-5	
equipment.....	2-11, 11-7, 13-44	
judges.....	2-11, 13-20	
judge's assignment limit .....	6-4	
judging change .....	7-6	
judging rate.....	7-5	
overload.....	7-7, 7-8	
premium list .....	9-3	
notice of change .....	7-8, 7-9	
rally exercises, signs .....	8-2	
ring conditions .....	2-11, 4-5	
ring size .....	4-5	
score sheets .....	10-9	
stewards .....	2-11	
trophies.....	2-11	
Online Event Management		
account ID .....	10-3	
additional information for an event .....	5-4	
club officer .....	10-3	
e-mail addresses .....	10-3	
event chairs .....	10-3	
event management.....	5-2	
log-in .....	5-2	
judge panel planning tool (JPP) .....	5-3	
Online Competition Management System (OCMS)		
.....	5-2	
password .....	10-3	
quick submit.....	5-4	
replication .....	5-2	
submitting a judges panel.....	5-3	
Organization Chart		
event committee .....	2-6	
<b>P</b>		
Parade of Title Holders.....	8-12	
Parent Club		
consent letter, designated specialty .....	8-4	
field titles.....	8-8	
local specialty club hosting .....	8-3	
number of events.....	10-6	
Parking		
alternate locations .....	4-7, 9-8	
concessionaires.....	2-15	
confirmations .....	2-15	
designated areas .....	4-8	
donation of fees .....	2-15	
emergency vehicles.....	2-14	
event committee members .....	2-14, 4-2	
event site .....	13-43, 13-45	
exhibitors .....	2-14, 4-2, 4-8	
fees .....	9-5	
handicapped .....	2-14, 4-8, 13-24, 13-28	
judges .....	2-14, 4-2	
judges' information.....	2-22	
on-street.....	4-7	
no-parking area .....	2-14	
overnight.....	2-15, 9-5, 9-8, 13-28	
reservations .....	2-15, 9-5	
RV's .....	2-14, 4-8, 13-28, 13-45	
site evaluation.....	13-43	
site inspection .....	13-28	
spectator .....	4-8	
stewards .....	2-14, 9-5	
Parking Fees		
collection area .....	4-9	
Treasurer .....	2-15	
Parking Pass		
exhibitor .....	4-9	
judges .....	2-22	
printing.....	11-7	
stewards .....	2-12	
Permission Letter.....	13-56	
Permits		
advertising posters .....	2-20	
event site .....	2-8	
street closure .....	4-7	

tenting.....	4-6, 10-11	trophies.....	2-18
Photographer		trophies, breed varieties.....	13-37
area for photographs.....	7-2	veteran sweepstakes.....	8-7
contract.....	2-8, 2-25, 13-14, 13-16, 13-61	video/televising.....	9-4, 10-12
exhibiting restrictions.....	2-7, 2-25	waiver of rights.....	13-64
Premium List.....	9-2	Printer	
Best Puppy in Show.....	8-9	advertising.....	2-17, 13-16
campgrounds.....	2-15	deadlines.....	11-7
catalog sales.....	9-9	trophy listing.....	2-18
closing date.....	9-3	Printing	
combined.....	9-2	errors.....	11-6, 11-8, 13-19
condensed.....	9-4	Provisional Judges	
copy for printer.....	13-15	education credit.....	6-2
deadline.....	11-8	minimum judging rate.....	7-3
designated specialty.....	8-4	recommended number.....	6-3
directions to event site.....	11-8	scheduling.....	7-3
entry fee.....	9-3	Public Address System.....	2-13, 13-16, 13-42, 13-44
errors.....	11-8	Publications.....	See AKC Publications
Event Committee members.....	9-3, 12-2	Publicity	
exercise pens.....	9-4	budget.....	2-19
exhibiting restrictions.....	2-6, 9-4	free.....	2-19
exhibitors' chairs.....	2-13	newsletters.....	2-20
futurity.....	8-6	paid.....	2-20
independent specialty.....	13-37	press release.....	2-20
judging on ramp.....	10-11	radio.....	2-19
local specialty club hosting.....	8-3	television.....	2-19
lodging.....	9-5	<b>R</b>	
mailing.....	10-2, 13-16	Rally.....	8-2
mailing deadline.....	10-2	Ramp, Judging.....	10-11
miscellaneous class.....	9-4	Grounds/Equipment Chair.....	2-13
motorized vehicles.....	13-22	judging schedule.....	7-2
multiple dog entries.....	8-8	premium list.....	9-4, 10-11
multiple dog entry limit.....	8-9	specifications.....	13-47
non-regular class ribbons.....	8-7	Records.....	See Event Records
non-regular classes.....	8-7	Refund	
obedience.....	9-3	entry fee.....	3-3, 7-5
OFA, CERF numbers.....	9-9	Reports	
official photographer.....	13-61	cluster site inspection.....	13-28
outdoor judging.....	4-3	Event Committee minutes.....	2-5
parking proceeds.....	2-15, 9-5	event financial report.....	2-24
printing.....	11-7, 11-8, 13-15	Hearing Committee.....	12-4, 13-26
private exercise pens.....	2-13, 9-4, 13-46	recording fee.....	11-5
proofreading.....	2-18, 11-8	Report of Dog Show or Obedience Trial ..	10-3, 11-5, 12-4, 13-19
recommended information.....	9-4	show results.....	2-8, 11-6
refund policy.....	3-3, 9-4	superintendent's financial report.....	11-5
required information.....	9-3	trophy income.....	2-18
rest areas.....	2-15	trophy inventory.....	2-18
service fees.....	9-3	Reservations	
Show Chair.....	2-8	lodging, judges.....	2-22, 13-15
show secretary address.....	11-8	parking.....	2-15
site map.....	9-5	Revenue	
space limitations.....	2-13	advertising.....	2-17
special attraction.....	8-10, 9-4	sharing, specialty.....	2-17
special awards.....	8-11	Ribbons	
superintendent/show secretary.....	9-3	Best of Variety.....	13-37
supported entry.....	8-4		
sweepstakes.....	8-6		

non-regular classes .....	8-7
obedience cluster .....	13-21
ordering .....	13-15
suppliers .....	10-9
sweepstakes, futurities .....	8-7
Ring Assignments	
Chief Steward .....	2-12, 13-17
Ring Conditions	
cleaning .....	4-4
enclosures .....	10-11
Grounds/Equipment Chair .....	2-13
materials .....	4-4
matting .....	4-4
obedience .....	4-5
Ring Layout	
aisles .....	4-5
conformation .....	2-12
group .....	4-6
group judging .....	7-2, 7-4
judging schedule .....	7-2
loading area supervisor .....	4-9
obedience .....	2-12, 4-5
ring size .....	4-5, 7-2
safe access .....	4-6
tenting .....	4-6
<b>S</b>	
Sanitation	
exercise pen conditions .....	4-10, 13-43, 13-45
facilities .....	2-13, 13-16, 13-29, 13-43, 13-45
outdoor toilet facility .....	4-9, 13-29, 13-45
rest rooms .....	4-3, 13-29
site evaluation .....	13-43
site selection .....	4-2
tools .....	4-9
trash bags .....	2-15
trash receptacles .....	2-13, 4-9
Scales .....	10-10
Schedule	
Best In Show .....	7-4
breed judging .....	7-3
break .....	7-3
group .....	7-4
Junior Showmanship .....	7-5
lunch .....	7-4
obedience .....	7-4
point .....	9-10
procedures .....	7-2
start time .....	7-2
Security .....	13-16
Service fees .....	9-3, 11-5
Show chair	
AKC Executive Field Representative .....	2-9
contracts .....	2-8
deadlines .....	2-7, 2-8
superintendent .....	2-8
Show Secretary .....	See Superintendent

Signs	
advertising .....	2-20
change of judge .....	11-5
concessions .....	2-15
directional arrows .....	2-13, 10-9, 13-16
exercise pens .....	13-29, 13-46
Grounds/Equipment Chair .....	2-13
no-parking .....	2-14
parking proceeds donation .....	2-15
printing .....	11-7
restrooms .....	2-13
telephones .....	2-13
to toilet facilities .....	13-45
traffic direction .....	4-8
unloading areas .....	4-8
unventilated vehicles .....	13-64, 13-65, 13-66
waiver of rights .....	13-64
Site	
affordability .....	4-2
approval .....	4-2
evaluating prospective .....	4-2
preparation .....	4-4
type .....	4-3
sharing .....	4-5
Site Access	
before event hours .....	2-13, 4-4, 11-8, 13-44
committee members .....	2-13
exhibitors .....	2-13, 9-7
superintendent .....	2-13
vendors .....	2-13
Site Inspection	
Executive Field Representative .....	2-24
Site Layout .....	10-8
concessions .....	2-16
Executive Field Representative .....	2-24
Event Operations .....	4-2
Grounds/Equipment Chair .....	2-13
map .....	2-13, 9-5, 9-8, 13-14
Obedience Chair .....	2-11
superintendent .....	11-8
tenting .....	4-6
Special Attractions	
clinics .....	8-10
form .....	8-10
judges .....	8-10
judge's assignment limit .....	6-4
law enforcement .....	8-10
Special awards .....	8-11
Specialty	
back-to-back .....	6-5, 10-6
catalog advertising .....	2-17
club officers .....	8-3, 8-4
combined .....	8-5
concurrent .....	8-5
contract .....	6-2
estimating entries .....	6-4
evening .....	8-5

futurity.....	8-8	layout.....	4-6
hosting parent club.....	8-3	Telephones	
judge's assignment limit.....	6-4	AKC directory.....	12-4
judges panel.....	6-2	emergency numbers.....	2-21, 6-7
judging assignments.....	6-3, 13-14	event site.....	4-4
liason.....	2-8	public.....	2-13
parent club consent.....	8-3	service.....	13-17
revenue-sharing with host club.....	2-17	signs.....	2-13
same day.....	8-5	veterinary clinic.....	2-21
specialty judge.....	8-4	Territory.....	10-4
supported entry limit.....	8-4, 8-5	cluster host club.....	10-5
sweepstakes.....	8-6	event site.....	4-2
veteran sweepstakes.....	8-7	geographically isolated.....	10-4
visiting judge limitation.....	6-3	supported entry.....	8-5
Stewards		Towing Services.....	2-15, 13-17, 13-45
admission ticket.....	2-12, 9-5	budgeting.....	3-2
Best in Show.....	2-12	inclement weather.....	4-8
chief.....	2-11, 13-18	Traffic Flow	
exhibiting.....	2-12	ambulance.....	2-14
judge's bag.....	2-12	emergency lanes.....	2-14
judging programs.....	2-12, 9-5	emergency plan.....	2-14
lunch tickets.....	2-12	emergency vehicles.....	4-7
obedience.....	2-11, 13-20	entry gate.....	4-8
parking passes.....	2-12, 9-5	event site.....	4-8
ring assignments.....	2-12	outdoor sites.....	4-9
scheduling.....	2-12, 9-5	personnel.....	13-16
show catalog.....	2-12	Parking Chair.....	2-14
stewarding organization.....	2-11, 13-11, 13-15	safety precautions.....	4-9
trophies.....	2-19	signs.....	4-8
Superintendent		site management.....	4-8
address lists.....	11-8	street closure.....	4-7
banners and signs, AKC.....	10-11	unloading area.....	4-8
canceling entries.....	11-5	Transportation	
contract.....	2-8, 11-2, 11-6, 11-8, 13-14	Hospitality Chair.....	2-22
correcting entries.....	11-4	judges.....	2-22, 2-23
designated specialty.....	8-4	Travel Arrangements	
event site.....	4-4	Hospitality Chair.....	2-22
financial report.....	11-5	judges.....	6-7
judges books.....	10-9, 11-6, 13-20	Trophies	
judging schedule.....	7-2, 11-6, 13-20	awards of merit.....	8-11
licensed.....	13-6	breed varieties.....	13-37
matting.....	4-4, 10-11	budget.....	2-18
meals.....	2-23	contract.....	2-18
premium list.....	9-3, 13-15	descriptions.....	2-18
report.....	10-9	designated specialty.....	8-4
services.....	11-7, 11-8	engraving.....	2-18, 13-16
site approval.....	4-2, 10-8, 13-18	in honor of dogs.....	2-18
tenting.....	4-6, 10-11, 11-7	in honor of people.....	2-18
T		judge's bag.....	2-19
Taxes		obedience.....	2-11
event site.....	2-8	perpetual.....	2-18, 13-16
Tenting		presentors.....	2-19
AKC policy.....	4-6	stewards.....	2-19
companies.....	13-12	three-time win.....	2-18, 9-4, 9-10
grooming.....	4-6, 4-10	veteran sweepstakes.....	8-7
guidelines.....	4-6, 13-44		

<b>V</b>		
Vendor		
confirmation .....	2-16	
contract.....	2-16	
generators .....	2-16	
rates.....	2-15	
space .....	2-15	
Veterinarian		
benched shows .....	2-21	
clinic hours.....	2-21	
contract.....	13-15, 13-45	
directions .....	2-21	
exhibiting restrictions .....	2-21	
location .....	2-21	
telephone number .....	2-21, 9-3, 9-7	
unbenched shows .....	2-21	
Videotaping		
AKC requirements .....	10-12	
event conditions .....	10-12	
		judges .....
		10-12
		judge's requirement .....
		10-15
		notice to Event Operations .....
		10-2
		notice to judges .....
		6-7, 13-57
		premium list .....
		9-4, 10-12
		<b>W</b>
		Water Supply .....
		2-13, 4-4, 13-17, 13-42, 13-44
		Weather Conditions
		event cancellation .....
		3-3
		judges' information.....
		2-22
		judging .....
		4-5
		National Weather Bureau .....
		4-3
		vehicle towing .....
		4-8
		Welfare, Animal
		crate labels .....
		13-67, 13-68
		scheduling judging.....
		7-3
		unventilated vehicles .....
		13-64, 13-65, 13-66
		Wickets .....
		10-10

**RESHOW (7/14)**